

# High-Speed M Series Multifunction DAQ 16-Bit, up to 1.25 MS/s, up to 32 Analog Inputs

## M Series – High-Speed

- 16 or 32 analog inputs at 16-bit, 1.25 MS/s (1 MS/s scanning)
- Up to 4 analog outputs at 16-bit, 2.8 MS/s (2  $\mu$ s full-scale settling)
- 7 programmable input ranges ( $\pm 100$  mV to  $\pm 10$  V) per channel
- Up to 48 TTL/CMOS digital I/O lines (up to 32 hardware-timed at 10 MHz)
- Two 32-bit, 80 MHz counter/timers
- Analog and digital triggering
- NI-MCal calibration technology for improved measurement accuracy
- 6 DMA channels for high-speed data throughput
- NI-DAQmx measurement services software for simplified configuration and measurements
- 3 year warranty

### Operating Systems

- Windows 2000/NT/XP

### Recommended Software

- LabVIEW
- LabWindows/CVI
- Measurement Studio

### Other Compatible Software

- NI SignalExpress
- Visual Studio .NET
- C/C++

### Measurement Services Software (included)

- NI-DAQmx

**NEW**



Family	Bus	Analog Inputs	Analog Input Resolution (bits)	Analog Outputs	Output Resolution (bits)	Max Output Rate (MS/s)	Output Range (V)	Digital I/O	Correlated (Clocked) DIO
NI 6250	PCI, PXI	16	16	0	—	—	—	24	8, up to 10 MHz
NI 6251	PCI, PXI	16	16	2	16	2.8	$\pm 10$	24	8, up to 10 MHz
NI 6254	PCI, PXI	32	16	0	—	—	—	48	32, up to 10 MHz
NI 6259	PCI, PXI	32	16	4	16	2.8	$\pm 10$	48	32, up to 10 MHz

Table 1. High-Speed M Series DAQ Model Guide

## Overview and Applications

National Instruments high-speed M Series devices are optimized for superior accuracy at fast sampling rates. They have an onboard NI-PGIA 2 amplifier designed for fast settling time at high scanning rates, ensuring 16-bit accuracy even when measuring all channels at maximum speeds. They are ideal for applications including test, control, and sensor measurements. For test, the analog inputs and 10 MHz digital lines can be used for applications including electronics test and component characterization. With the fast sampling rates, they can accurately acquire dynamic signals. High-speed M Series devices also have quadrature encoder inputs, protected digital lines, and digital debounce filters for control applications. With four waveform analog outputs and two 80 MHz counter/timers, M Series devices can execute multiple control loops simultaneously and can control pulse-width modulated signals. For sensor measurements, M Series devices are compatible with SCC and SCXI signal conditioning, and can measure IEEE 1451.4 smart sensors. Synchronize the operations of multiple devices using the RTSI bus or PXI trigger bus.

## Recommended Accessories

Signal conditioning is required for sensor measurements or voltage inputs greater than 10 V. National Instruments SCXI is a versatile, high-performance signal conditioning platform, optimized for high-channel-count applications. NI SCC provides portable, flexible signal conditioning options on a per-channel basis. For applications not requiring signal conditioning, refer to the table below for recommended cabling and accessories.

System Description	Terminal Block	Cable
High Performance	SCB-68, BNC-2110, TBX-68	SHC68-68-EPM
Basic Shielding	SCB-68, BNC-2110, TBX-68	SHC68-68-S

Table 2. Recommended Accessories (Two cables and accessories are required to access all pins on the NI 6254 and 6259 devices.)

# High-Speed M Series Multifunction DAQ

## 16-Bit, up to 1.25 MS/s, up to 32 Analog Inputs

AI 0	68	34	AI 8
AI GND	67	33	AI 1
AI 9	66	32	AI GND
AI 2	65	31	AI 10
AI GND	64	30	AI 3
AI 11	63	29	AI GND
AI SENSE	62	28	AI 4
AI 12	61	27	AI GND
AI 5	60	26	AI 13
AI GND	59	25	AI 6
AI 14	58	24	AI GND
AI 7	57	23	AI 15
AI GND	56	22	NC
NC	55	21	NC
NC	54	20	APFI 0
D GND	53	19	P0.4
P0.0	52	18	D GND
P0.5	51	17	P0.1
D GND	50	16	P0.6
P0.2	49	15	D GND
P0.7	48	14	+5 V
P0.3	47	13	D GND
PFI 11/P2.3	46	12	D GND
PFI 10/P2.2	45	11	PFI 0/P1.0
D GND	44	10	PFI 1/P1.1
PFI 2/P1.2	43	9	D GND
PFI 3/P1.3	42	8	+5 V
PFI 4/P1.4	41	7	D GND
PFI 13/P2.5	40	6	PFI 5/P1.5
PFI 15/P2.7	39	5	PFI 6/P1.6
PFI 7/P1.7	38	4	D GND
PFI 8/P2.0	37	3	PFI 9/P2.1
D GND	36	2	PFI 12/P2.4
D GND	35	1	PFI 14/P2.6

NC = No Connect

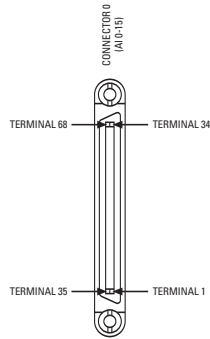

AI 0	68	34	AI 8
AI GND	67	33	AI 1
AI 9	66	32	AI GND
AI 2	65	31	AI 10
AI GND	64	30	AI 3
AI 11	63	29	AI GND
AI SENSE	62	28	AI 4
AI 12	61	27	AI GND
AI 5	60	26	AI 13
AI GND	59	25	AI 6
AI 14	58	24	AI GND
AI 7	57	23	AI 15
AI GND	56	22	NC
NC	55	21	NC
NC	54	20	APFI 0
D GND	53	19	P0.4
P0.0	52	18	D GND
P0.5	51	17	P0.1
D GND	50	16	P0.6
P0.2	49	15	D GND
P0.7	48	14	+5 V
P0.3	47	13	D GND
PFI 11/P2.3	46	12	D GND
PFI 10/P2.2	45	11	PFI 0/P1.0
D GND	44	10	PFI 1/P1.1
PFI 2/P1.2	43	9	D GND
PFI 3/P1.3	42	8	+5 V
PFI 4/P1.4	41	7	D GND
PFI 13/P2.5	40	6	PFI 5/P1.5
PFI 15/P2.7	39	5	PFI 6/P1.6
PFI 7/P1.7	38	4	D GND
PFI 8/P2.0	37	3	PFI 9/P2.1
D GND	36	2	PFI 12/P2.4
D GND	35	1	PFI 14/P2.6

NC = No Connect

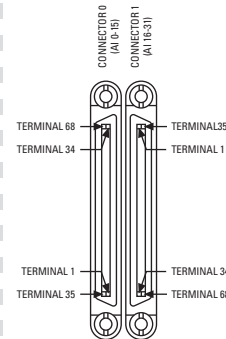

P0.30	1	35	D GND
P0.28	2	36	D GND
P0.25	3	37	P0.24
D GND	4	38	P0.23
P0.22	5	39	P0.31
P0.21	6	40	P0.29
D GND	7	41	P0.20
+5 V	8	42	P0.19
D GND	9	43	P0.18
P0.17	10	44	D GND
P0.16	11	45	P0.26
D GND	12	46	P0.27
D GND	13	47	P0.11
+5 V	14	48	P0.15
D GND	15	49	P0.10
P0.14	16	50	D GND
P0.9	17	51	P0.13
D GND	18	52	P0.8
P0.12	19	53	D GND
APFI 1	20	54	NC
NC	21	55	NC
AI GND	22	56	AI GND
AI 31	23	57	AI 23
AI GND	24	58	AI 30
AI 22	25	59	AI GND
AI 29	26	60	AI 21
AI GND	27	61	AI 28
AI 20	28	62	AI SENSE 2
AI GND	29	63	AI 27
AI 19	30	64	AI GND
AI 26	31	65	AI 18
AI GND	32	66	AI 25
AI 17	33	67	AI GND
AI 24	34	68	AI 16

NC = No Connect

NI 6250 Pinout

NI 6254 Pinout

AI 0	68	34	AI 8
AI GND	67	33	AI 1
AI 9	66	32	AI GND
AI 2	65	31	AI 10
AI GND	64	30	AI 3
AI 11	63	29	AI GND
AI SENSE	62	28	AI 4
AI 12	61	27	AI GND
AI 5	60	26	AI 13
AI GND	59	25	AI 6
AI 14	58	24	AI GND
AI 7	57	23	AI 15
AI GND	56	22	AO 0
AO GND	55	21	AO 1
AO GND	54	20	APFI 0
D GND	53	19	P0.4
P0.0	52	18	D GND
P0.5	51	17	P0.1
D GND	50	16	P0.6
P0.2	49	15	D GND
P0.7	48	14	+5 V
P0.3	47	13	D GND
PFI 11/P2.3	46	12	D GND
PFI 10/P2.2	45	11	PFI 0/P1.0
D GND	44	10	PFI 1/P1.1
PFI 2/P1.2	43	9	D GND
PFI 3/P1.3	42	8	+5 V
PFI 4/P1.4	41	7	D GND
PFI 13/P2.5	40	6	PFI 5/P1.5
PFI 15/P2.7	39	5	PFI 6/P1.6
PFI 7/P1.7	38	4	D GND
PFI 8/P2.0	37	3	PFI 9/P2.1
D GND	36	2	PFI 12/P2.4
D GND	35	1	PFI 14/P2.6

NI 6251 Pinout

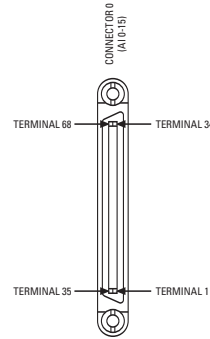

AI 0	68	34	AI 8
AI GND	67	33	AI 1
AI 9	66	32	AI GND
AI 2	65	31	AI 10
AI GND	64	30	AI 3
AI 11	63	29	AI GND
AI SENSE	62	28	AI 4
AI 12	61	27	AI GND
AI 5	60	26	AI 13
AI GND	59	25	AI 6
AI 14	58	24	AI GND
AI 7	57	23	AI 15
AI GND	56	22	AO 0
AO GND	55	21	AO 1
AO GND	54	20	APFI 0
D GND	53	19	P0.4
P0.0	52	18	D GND
P0.5	51	17	P0.1
D GND	50	16	P0.6
P0.2	49	15	D GND
P0.7	48	14	+5 V
P0.3	47	13	D GND
PFI 11/P2.3	46	12	D GND
PFI 10/P2.2	45	11	PFI 0/P1.0
D GND	44	10	PFI 1/P1.1
PFI 2/P1.2	43	9	D GND
PFI 3/P1.3	42	8	+5 V
PFI 4/P1.4	41	7	D GND
PFI 13/P2.5	40	6	PFI 5/P1.5
PFI 15/P2.7	39	5	PFI 6/P1.6
PFI 7/P1.7	38	4	D GND
PFI 8/P2.0	37	3	PFI 9/P2.1
D GND	36	2	PFI 12/P2.4
D GND	35	1	PFI 14/P2.6

NI 6259 Pinout

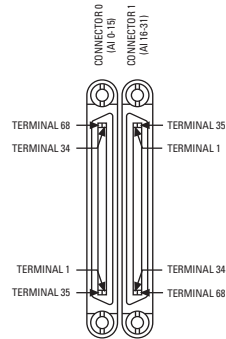

P0.30	1	35	D GND
P0.28	2	36	D GND
P0.25	3	37	P0.24
D GND	4	38	P0.23
P0.22	5	39	P0.31
P0.21	6	40	P0.29
D GND	7	41	P0.20
+5 V	8	42	P0.19
D GND	9	43	P0.18
P0.17	10	44	D GND
P0.16	11	45	P0.26
D GND	12	46	P0.27
D GND	13	47	P0.11
+5 V	14	48	P0.15
D GND	15	49	P0.10
P0.14	16	50	D GND
P0.9	17	51	P0.13
D GND	18	52	P0.8
P0.12	19	53	D GND
APFI 1	20	54	AO GND
AO 3	21	55	AO GND
AO 2	22	56	AI GND
AI 31	23	57	AI 23
AI GND	24	58	AI 30
AI 22	25	59	AI GND
AI 29	26	60	AI 21
AI GND	27	61	AI 28
AI 20	28	62	AI SENSE 2
AI GND	29	63	AI 27
AI 19	30	64	AI GND
AI 26	31	65	AI 18
AI GND	32	66	AI 25
AI 17	33	67	AI GND
AI 24	34	68	AI 16

# High-Speed M Series Multifunction DAQ 16-Bit, up to 1.25 MS/s, up to 32 Analog Inputs

## Ordering Information

### PCI

NI PCI-6250 .....	779069-01
NI PCI-6251 .....	779070-01
NI PCI-6254 .....	779071-01
NI PCI-6259 .....	779072-01

### PXI

NI PXI-6250 .....	779116-01
NI PXI-6251 .....	779117-01
NI PXI-6254 .....	779118-01
NI PXI-6259 .....	779119-01

Includes NI-DAQmx Measurement Services Software.

## BUY ONLINE!

For complete product specifications, pricing, and accessory information, call (800) 813-3693 (U.S. only) or go to [ni.com/daq](http://ni.com/daq).

## Specifications

Typical at 25 °C unless otherwise noted.

### Analog Input

Number of channels	
NI 6250/NI 6251 .....	8 differential or 16 single ended
NI 6254/NI 6259 .....	16 differential or 32 single ended
ADC resolution .....	
	16 bits
DNL .....	
	No missing codes guaranteed
INL .....	
	Refer to the <i>AI Absolute Accuracy Table</i>
Sampling rate	
Maximum .....	1.25 MS/s single-channel 1.00 MS/s multichannel
Minimum .....	0 S/s
Timing accuracy .....	50 ppm of sample rate
Timing resolution .....	50 ns
Input coupling .....	
	DC
Input range .....	
	$\pm 10$ , $\pm 5$ , $\pm 2$ , $\pm 1$ , $\pm 0.5$ , $\pm 0.2$ , $\pm 0.1$ V
Maximum working voltage for analog inputs (signal + common mode) .....	
	$\pm 11$ V of AI GND
CMRR (DC to 60 Hz) .....	
	100 dB
Input impedance	
AI+ to AI GND .....	>10 G $\Omega$ in parallel with 100 pF
AI- to AI GND .....	>10 G $\Omega$ in parallel with 100 pF
Input bias current .....	
	$\pm 100$ pA
Crosstalk (at 100 kHz)	
Adjacent channels .....	-75 dB
Nonadjacent channels .....	-95 dB
Small signal bandwidth (-3 dB) .....	
	1.7 MHz
Input FIFO size .....	
	4,095 samples
Scan list memory .....	
	4,095 entries
Data transfers .....	
	DMA (scatter-gather), interrupts, programmed I/O
Overvoltage protection	
(AI <0..31>, AI SENSE, AI SENSE 2)	
Device on .....	$\pm 25$ V for up to 4 AI pins
Device off .....	$\pm 15$ V for up to 4 AI pins
Input current during overvoltage condition .....	
	$\pm 20$ mA max/AI pin

### Settling Time for Multichannel Measurements

Range (V)	$\pm 60$ ppm of Step ( $\pm 4$ LSB for Full Scale Step)	$\pm 15$ ppm of Step ( $\pm 1$ LSB for Full Scale Step)
$\pm 10$ , $\pm 5$ , $\pm 2$ , $\pm 1$	1 $\mu$ s	1.5 $\mu$ s
$\pm 0.5$	1.5 $\mu$ s	2 $\mu$ s
$\pm 0.2$ , $\pm 0.1$	2 $\mu$ s	8 $\mu$ s

## Typical Performance Graphs

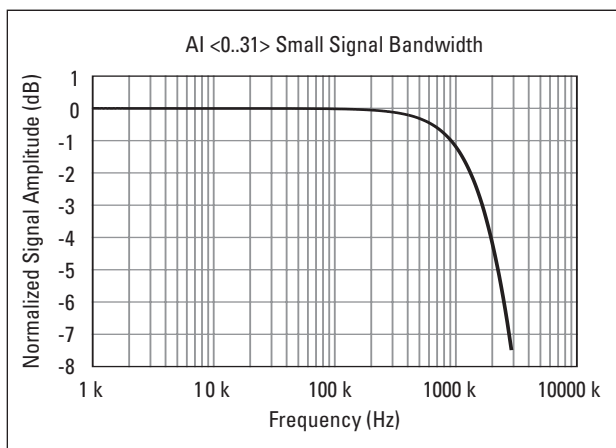
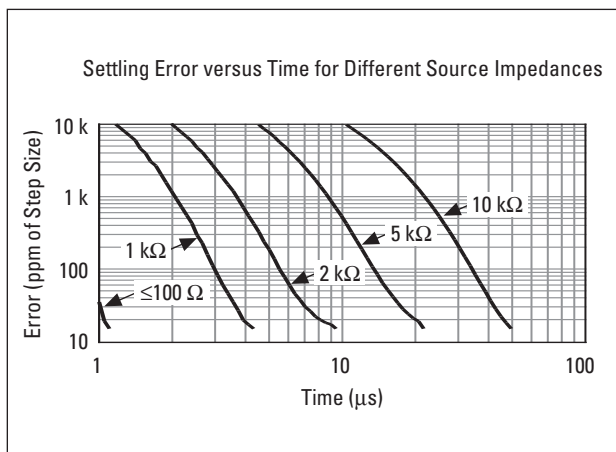

# High-Speed M Series Multifunction DAQ

## 16-Bit, up to 1.25 MS/s, up to 32 Analog Inputs

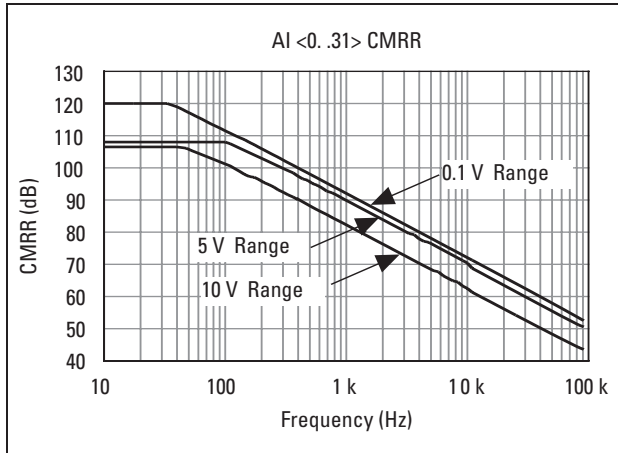

### Analog Triggers

Number of triggers	1
Source	
NI 6250/NI 6251	AI <0..15>, APFI 0
NI 6254/NI 6259	AI <0..31>, APFI <0..1>
Functions	Start Trigger, Reference Trigger, Pause Trigger, Sample Clock, Convert Clock, Sample Clock Timebase
Source level	
(AI <0..31>)	±full scale
(APFI <0..1>)	±10 V
Resolution	10 bits, 1 in 1,024
Modes	Level triggering, level triggering with hysteresis, window triggering
Bandwidth (-3 dB)	
AI <0..31>	3.4 MHz
APFI <0..1>	3.9 MHz
Accuracy	±1%
APFI <0..1> characteristics	
Input impedance	10 kΩ
Coupling	DC
Protection	
Power on	±30 V
Power off	±15 V

### AI Absolute Accuracy Table

Nominal Range	Residual Gain Error	Gain Tempco	Reference Tempco	Residual Offset Error	Offset Tempco	INL Error	Random Noise, σ (μV <sub>rms</sub> )	Absolute Accuracy at Full Scale <sup>1</sup> (μV)	Sensitivity <sup>2</sup> (μV)
10	60	13	1	20	21	60	280	1920	112.0
5	70	13	1	20	21	60	140	1010	56.0
2	70	13	1	20	24	60	57	410	22.8
1	80	13	1	20	27	60	32	220	12.8
0.5	90	13	1	40	34	60	21	130	8.4
0.2	130	13	1	80	55	60	16	74	6.4
0.1	150	13	1	150	90	60	15	52	6.0

AbsoluteAccuracy = Reading · (GainError) + Range · (OffsetError) + NoiseUncertainty

GainError = ResidualGainError + GainTempco · (TempChangeFromLastInternalCal) + ReferenceTempco · (TempChangeFromLastExternalCal)

OffsetError = ResidualOffsetError + OffsetTempco · (TempChangeFromLastInternalCal) + INL\_Error

NoiseUncertainty =  $\frac{\text{RandomNoise} \cdot 3}{\sqrt{100}}$ , For a coverage factor of 3 σ and averaging 100 points

<sup>1</sup> Absolute accuracy at full scale on the analog input channels is determined using the following assumptions:

TempChangeFromLastExternalCal = 10 °C

TempChangeFromLastInternalCal = 1 °C

number\_of\_readings = 100

CoverageFactor = 3 σ

For example, on the 10 V range, the absolute accuracy at full scale is as follows:

GainError = 60 ppm + 13 ppm · 1 + 1 ppm · 10      GainError = 83 ppm

OffsetError = 20 ppm + 21 ppm · 1 + 60 ppm      OffsetError = 101 ppm

NoiseUncertainty =  $\frac{275 \mu\text{V} \cdot 3}{\sqrt{100}}$ , NoiseUncertainty = 83 μV

AbsoluteAccuracy = 10 V · (GainError) + 10 V · (OffsetError) + NoiseUncertainty

AbsoluteAccuracy = 1920 μV

<sup>2</sup> Sensitivity is the smallest voltage change that can be detected. It is a function of noise.

# High-Speed M Series Multifunction DAQ

## 16-Bit, up to 1.25 MS/s, up to 32 Analog Inputs

### Analog Output

Number of channels	
NI 6250 .....	0
NI 6251 .....	2
NI 6254 .....	0
NI 6259 .....	4
DAC resolution .....	16 bits
DNL .....	±1 LSB
Monotonicity .....	16 bit guaranteed
Accuracy .....	Refer to the <i>AO Absolute Accuracy Table</i>
Maximum update rate	
1 channel .....	2.86 MS/s
2 channels .....	2.00 MS/s
3 channels .....	1.54 MS/s
4 channels .....	1.25 MS/s
Timing accuracy .....	50 ppm of sample rate
Timing resolution .....	50 ns
Output range .....	±10 V, ±5 V, ±external reference on APFI <0..1>

Output coupling .....	DC
Output impedance .....	0.2 Ω
Output current drive .....	±5 mA
Overdrive protection .....	±25 V
Overdrive current .....	20 mA
Power-on state .....	±5 mV
Power-on glitch .....	1.5 V peak for 1.5 s
Output FIFO size .....	8,191 samples shared among channels used
Data transfers .....	DMA (scatter-gather), interrupts, programmed I/O
AO waveform modes:	
• Non-periodic waveform	
• Periodic waveform regeneration mode from onboard FIFO	
• Periodic waveform regeneration from host buffer including dynamic update	
Settling time, full scale step	
15 ppm (1 LSB) .....	2 μs
Slew rate .....	20 V/μs
Glitch energy at midscale transition, ±10 V range	
Magnitude .....	10 mV
Duration .....	1 μs

### AO Absolute Accuracy Table

Nominal Range		Residual Gain Error (ppm of Reading)	Gain Tempco (ppm/°C)	Reference Tempco	Residual Offset Error (ppm of Range)	Offset Tempco (ppm of Range/°C)	INL Error (ppm of Range)	Absolute Accuracy at Full Scale <sup>1</sup> (μV)
Positive Full Scale	Negative Full Scale							
10	-10	75	17	1	40	2	64	2080
5	-5	85	8	1	40	2	64	1045

<sup>1</sup> Absolute Accuracy at full scale numbers is valid immediately following internal calibration and assume the device is operating within 10 °C of the last external calibration.

$$\text{AbsoluteAccuracy} = \text{OutputValue} \cdot (\text{GainError}) + \text{Range} \cdot (\text{OffsetError})$$

$$\text{GainError} = \text{ResidualGainError} + \text{GainTempco} \cdot (\text{TempChangeFromLastInternalCal}) + \text{ReferenceTempco} \cdot (\text{TempChangeFromLastExternalCal})$$

$$\text{OffsetError} = \text{ResidualOffsetError} + \text{AOOffsetTempco} \cdot (\text{TempChangeFromLastInternalCal}) + \text{INL\_Error}$$

### External Reference

APFI <0..1> characteristics	
Input impedance .....	10 kΩ
Coupling .....	DC
Protection	
Power on .....	±30 V
Power off .....	±15 V
Range .....	±11 V
Slew rate .....	20 V/μs

### Calibration (AI and AO)

Recommended warm-up time .....	15 minutes
Calibration interval .....	2 years

### Digital I/O/PFI

#### Static Characteristics

Number of channels	
NI 6250/NI 6251 .....	24 total
	8 (P0.<0..7>)
	16 (PFI <0..7>/P1, PFI <8..15>/P2)
NI 6254/NI 6259 .....	48 total
	32 (P0.<0..31>)
	16 (PFI <0..7>/P1, PFI <8..15>/P2)
Ground reference .....	
	D GND
Direction control .....	
	Each terminal individually programmable as input or output
Pull-down resistor .....	50 to 75 kΩ
Input voltage protection <sup>1</sup> .....	±20 V on up to two pins

<sup>1</sup> Stresses beyond those listed under input voltage protection may cause permanent damage to the device.

#### Waveform Characteristics (Port 0 Only)

Terminals used	
NI 6250/NI 6251 .....	Port 0 (P0.<0..7>)
NI 6254/NI 6259 .....	Port 0 (P0.<0..31>)
Port/sample size	
NI 6250/NI 6251 .....	Up to 8 bits
NI 6254/NI 6259 .....	Up to 32 bits
Waveform generation (DO) FIFO .....	2,047 samples
Waveform acquisition (DI) FIFO .....	2,047 samples
DO or DI Sample Clock frequency .....	0 to 10 MHz
DO or DI Sample Clock source <sup>1</sup> .....	Any PFI, RTSI, AI Sample or Convert Clock, AO Sample Clock, Ctr <i>n</i> Internal Output, and many other signals

<sup>1</sup> The digital subsystem does not have its own dedicated internal timing engine. Therefore, a sample clock must be provided from another subsystem on the device or an external source.

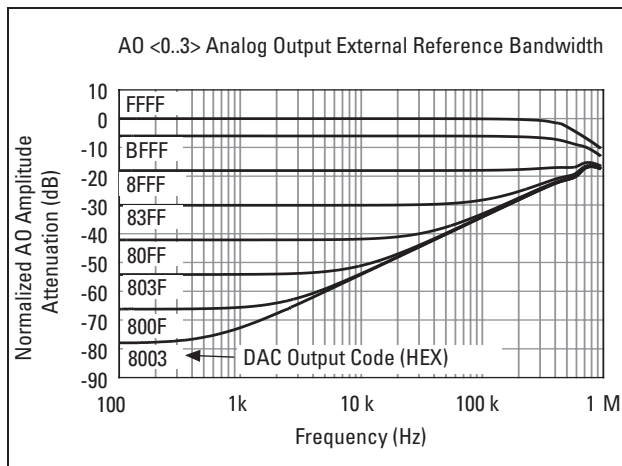

# High-Speed M Series Multifunction DAQ

## 16-Bit, up to 1.25 MS/s, up to 32 Analog Inputs

### PFI/Port 1/Port 2 Functionality

Functionality.....	Static digital input, static digital output, timing input, timing output
Timing output sources.....	Many AI, AO, counter, DI, DO timing signals
Debounce filter settings.....	125 ns, 6.425 $\mu$ s, 2.54 ms, disable; high and low transitions; selectable per input

### Recommended Operation Conditions

Level	Minimum	Maximum
Input high voltage ( $V_{IH}$ )	2.2 V	5.25 V
Input low voltage ( $V_{IL}$ )	0 V	0.8 V
Output high current ( $I_{OH}$ )		
P0.<0..31>	-	-24 mA
PFI.<0..15>/P1/P2	-	-16 mA
Output low current ( $I_{OL}$ )		
P0.<0..31>	-	24 mA
PFI.<0..15>/P1/P2	-	16 mA

### Electrical Characteristics

Level	Minimum	Maximum
Positive-going threshold ( $V_{T+}$ )	-	2.2 V
Negative-going threshold ( $V_{T-}$ )	0.8 V	-
Delta VT hysteresis ( $V_{T+} - V_{T-}$ )	0.2 V	-
$I_{IL}$ input low current ( $V_{in} = 0$ V)	-	-10 $\mu$ A
$I_{IH}$ input high current ( $V_{in} = 5$ V)	-	250 $\mu$ A

### Digital I/O Characteristics

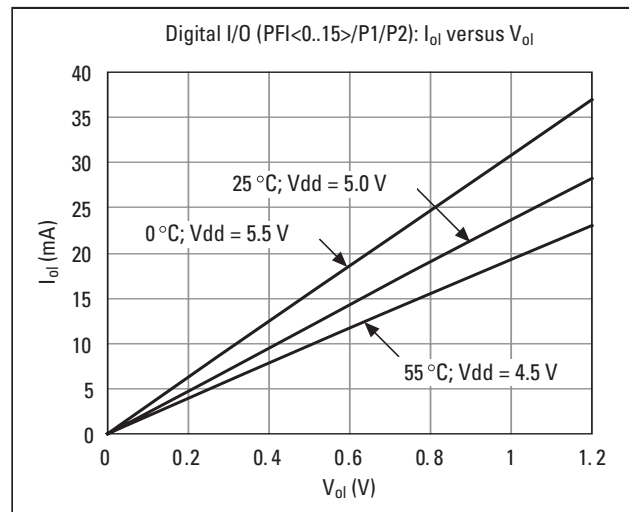
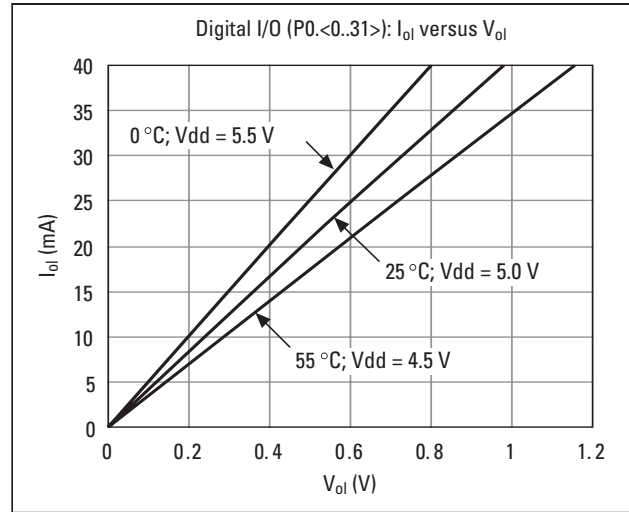
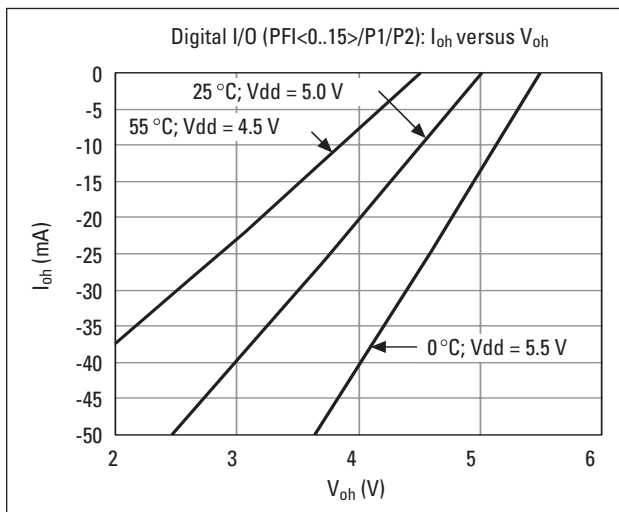
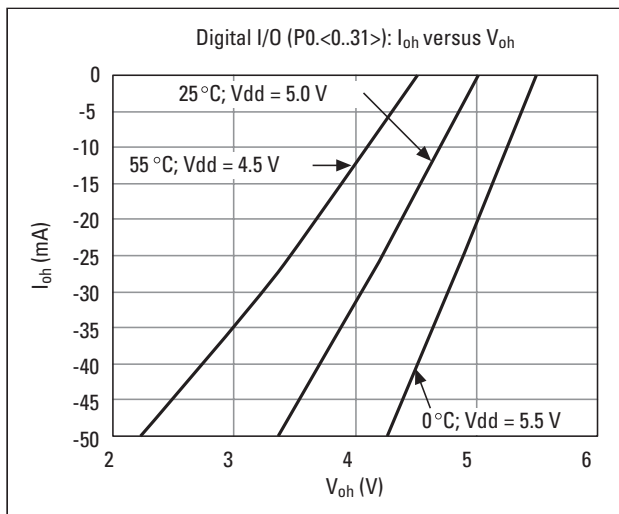

### General-Purpose Counter/Timers

Number of counter/timers.....	2
Resolution.....	32 bits
Counter measurements.....	Edge counting, pulse, semiperiod, period, two-edge separation
Position measurements.....	X1, X2, X4 quadrature encoding with Channel Z reloading; two-pulse encoding
Output applications.....	Pulse, pulse train with dynamic updates, frequency division, equivalent time sampling
Internal base clocks.....	80, 20, 0.1 MHz
External base clock frequency.....	0 to 20 MHz
Base clock accuracy.....	50 ppm
Inputs.....	Gate, Source, HW_Arm, Aux, A, B, Z, Up_Down
Routing options for inputs.....	Any PFI, RTSI, PXL_TRIG, PXL_STAR, analog trigger, many internal signals
FIFO.....	2 samples
Data transfers.....	Dedicated scatter-gather DMA controller for each counter/timer; interrupts; programmed I/O

### Frequency Generator

Number of channels.....	1
Base clocks.....	10 MHz, 100 kHz
Divisors.....	1 to 16
Base clock accuracy.....	50 ppm
Output can be available on any PFI or RTSI terminal.	

# High-Speed M Series Multifunction DAQ

## 16-Bit, up to 1.25 MS/s, up to 32 Analog Inputs

### Phase-Locked Loop (PLL)

Number of PLLs .....	1
Reference signal .....	PXL_STAR, PXL_CLK10, RTSI <0..7>
Output of PLL .....	80 MHz Timebase; other signals derived from 80 MHz Timebase including 20 MHz and 100 kHz Timebases

### External Digital Triggers

Source .....	Any PFI, RTSI, PXL_TRIG, PXL_STAR
Polarity .....	Software-selectable for most signals
Analog input function .....	Start Trigger, Reference Trigger, Pause Trigger, Sample Clock, Convert Clock, Sample Clock Timebase
Analog output function .....	Start Trigger, Pause Trigger, Sample Clock, Sample Clock Timebase
Counter/timer functions .....	Gate, Source, HW_Arm, Aux, A, B, Z, Up_Down
Digital waveform generation (DO) function .....	Sample Clock
Digital waveform acquisition (DI) function .....	Sample Clock

### Device-To-Device Trigger Bus

PCI .....	RTSI <0..7> <sup>1</sup>
PXI .....	PXL_TRIG <0..7>, PXL_STAR
Output selections .....	10 MHz Clock; frequency generator output; many internal signals
Debounce filter settings .....	125 ns, 6.425 $\mu$ s, 2.54 ms, disable; high and low transitions; selectable per input

<sup>1</sup> In other sections of this document, RTSI refers to RTSI <0..7> for PCI devices or PXL\_TRIG <0..7> for PXI devices.

### Bus Interface

PCI or PXI .....	3.3 V or 5 V signal environment
DMA channels .....	6, analog input, analog output, digital input, digital output, counter/timer 0, counter/timer 1

### Power Requirements

Current draw from bus during no-load condition	
+5 V .....	0.03 A
+3.3 V .....	0.725 A
+12 V .....	0.35 A
Current draw from bus during AI and AO overvoltage condition	
+5 V .....	0.03 A
+3.3 V .....	1.2 A
+12 V .....	0.38 A
Power available from +5 V terminal .....	1 A max, each connector, with self-resetting fuse
Other power limit for PXI devices .....	Current drawn from +5 V terminals and all P0/PFI/P1/P2 terminals should not exceed 2 A

### Physical

Dimensions	
PCI .....	9.7 cm by 15.5 cm (3.8 in. by 6.1 in.)
PXI .....	Standard 3U PXI
I/O connectors	
NI 6250/NI 6251 .....	1 68-pin VHDCI
NI 6254/NI 6259 .....	2 68-pin VHDCI

### Maximum Working Voltage<sup>1</sup>

Channel-to-earth ..... 11 V, Measurement Category I

Caution: Do not use for measurements within Categories II, III, or IV.

<sup>1</sup> Maximum working voltage refers to the signal voltage plus the common-mode voltage.

### Environmental

Operating temperature .....	0 to 55 °C
Storage temperature .....	-20 to 70 °C
Relative humidity .....	10 to 90% noncondensing
Maximum altitude .....	2,000 m
Pollution Degree (indoor use only) .....	2

### Safety

This product is designed to meet the requirements of the following standards of safety for electrical equipment for measurement, control, and laboratory use:

- IEC 61010-1, EN 61010-1
- UL 61010-1
- CAN/CSA-C22.2 No. 61010.1

For UL and other safety certifications, refer to the product label, or visit [ni.com/certification](http://ni.com/certification), search by model number or product line, and click the appropriate link in the Certification column.

### Electromagnetic Compatibility

Emissions .....	EN 55011 Class A at 10 m FCC Part 15A above 1 GHz
Immunity .....	EN 61326:1997 + A2:2001, Table 1

CE, C-Tick, and FCC Part 15 (Class A) Compliant

For EMC compliance, operate this device with shielded cabling.

### CE Compliance

This product meets the essential requirements of applicable European Directives, as amended for CE Marking, as follows:

Low-Voltage Directive (safety) .....	73/23/EEC
Electromagnetic Compatibility Directive (EMC) .....	89/336/EEC

Refer to the Declaration of Conformity (DoC) for this product for any additional regulatory compliance information. To obtain the DoC for this product, visit [ni.com/certification](http://ni.com/certification), search by model number or product line, and click the appropriate link in the Certification column.

# NI Services and Support

NI has the services and support to meet your needs around the globe and through the application life cycle – from planning and development through deployment and ongoing maintenance. We offer services and service levels to meet customer requirements in research, design, validation, and manufacturing. Visit [ni.com/services](http://ni.com/services) for more information.

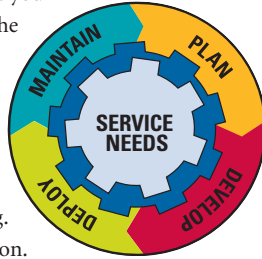

## Training and Certification

NI training is the fastest, most certain route to productivity with our products. NI training can shorten your learning curve, save development time, and reduce maintenance costs over the application life cycle. NI schedules instructor-led courses in cities worldwide, or can hold a course at your facility. NI also offers a professional certification program that identifies individuals who have high levels of skill and knowledge on using NI products. Visit [ni.com/training](http://ni.com/training).

## Professional Services

The NI Professional Services Team is comprised of NI applications engineers, NI consulting services, and a worldwide National Instruments Alliance Partner Program of more than 600 independent consultants and integrators. Services range from start-up assistance to turnkey system integration. Visit [ni.com/alliance](http://ni.com/alliance) for more information.



## OEM Support

We offer design-in consulting and product integration assistance if you want to use our products for OEM applications. For information about special pricing and services for OEM customers, visit [ni.com/oem](http://ni.com/oem) for more information.

## Local Sales and Technical Support

In offices worldwide, NI staff is local to the country, giving you access to engineers who speak your language. NI delivers industry-leading technical support through an online KnowledgeBase, applications engineers, and access to 14,000 measurement and automation professionals within NI Developer Exchange forums. Find immediate answers to your questions at [ni.com/support](http://ni.com/support).

We also offer service programs that provide automatic upgrades to your application development environment and higher levels of technical support. Visit [ni.com/ssp](http://ni.com/ssp).

## Hardware Services

### NI Factory Installation Services

NI Factory Installation Services (FIS) is the fastest and easiest way to use your PXI or PXI/SCXI combination systems right out of the box. Trained NI technicians install the software and hardware and configure the system to your specifications. NI extends the standard warranty by one year on hardware components (controllers, chassis, modules) purchased with FIS. To use FIS, simply configure your system online with [ni.com/pxiadvisor](http://ni.com/pxiadvisor).

### Calibration Services

NI recognizes the need to maintain properly calibrated devices for high-accuracy measurements. We provide manual calibration procedures, services to recalibrate your products, and automated calibration software specifically designed for use by metrology laboratories. Visit [ni.com/calibration](http://ni.com/calibration).

### Repair and Extended Warranty

NI provides complete repair services for our products. Express repair and advance replacement services are also available. We offer extended warranties to help you meet project life-cycle requirements. Visit [ni.com/services](http://ni.com/services).



[ni.com](http://ni.com) • (800) 813 3693

National Instruments • [info@ni.com](mailto:info@ni.com)