

**NuIPC[®] / NuDAQ[®]
cPCI-7252, PCI-7250/7251
Relay Actuator &
Isolated D/I Cards
User's Guide**



Recycled Paper

©Copyright 1997~2002 ADLINK Technology Inc.
All Rights Reserved.

Manual Rev. 2.52: September 16, 2002
Part No: 50-11105-101

The information in this document is subject to change without prior notice in order to improve reliability, design and function and does not represent a commitment on the part of the manufacturer.

In no event will the manufacturer be liable for direct, indirect, special, incidental, or consequential damages arising out of the use or inability to use the product or documentation, even if advised of the possibility of such damages.

This document contains proprietary information protected by copyright. All rights are reserved. No part of this manual may be reproduced by any mechanical, electronic, or other means in any form without prior written permission of the manufacturer.

Trademarks

NuDAQ[®], NuIPC[®], DAQBench are registered trademarks of ADLINK Inc. Other product names mentioned herein are used for identification purposes only and may be trademarks and/or registered trademarks of their respective companies.

Getting service from ADLINK

- Customer Satisfaction is the most important priority for ADLINK Tech Inc. If you need any help or service, please contact us.

ADLINK Technology Inc.			
Web Site	http://www.adlinktech.com		
Sales & Service	Service@adlinktech.com		
Technical Support	NuDAQ + USBDAQ	nudaq@adlinktech.com	
	Automation	automation@adlinktech.com	
	NuIPC	nuipc@adlinktech.com	
	NuPRO / EBC	nupro@adlinktech.com	
TEL	+886-2-82265877	FAX	+886-2-82265717
Address	9F, No. 166, Jian Yi Road, Chungho City, Taipei, 235 Taiwan.		

- Please email or FAX us of your detailed information for a prompt, satisfactory and constant service.

Detailed Company Information			
Company/Organization			
Contact Person			
E-mail Address			
Address			
Country			
TEL		FAX	
Web Site			
Questions			
Product Model			
Environment to Use	OS: Computer Brand: M/B: CPU: Chipset: BIOS: Video Card: Network Interface Card: Other:		
Detail Description			
Suggestions to ADLINK			

Table of Contents

List of Tables and Figures	iii
How to Use This Guide	iv
Introduction	1
1.1 Features.....	2
1.2 Applications	2
1.3 Specifications.....	3
1.3.1 <i>Digital input</i>	3
1.3.2 <i>Relay Output</i>	3
1.3.3 <i>General Specifications</i>	4
1.3.4 <i>Power Consumption</i>	4
1.4 Software Supporting	5
1.4.1 <i>Programming Library</i>	5
1.4.2 <i>PCIS-LVIEW: LabVIEW® Driver</i>	6
1.4.3 <i>PCIS-VEE: HP-VEE Driver</i>	6
1.4.4 <i>DAQBench™: ActiveX Controls</i>	6
1.4.5 <i>PCIS-DDE: DDE Server and InTouch™</i>	6
1.4.6 <i>PCIS-ISG: ISaGRAF™ driver</i>	6
1.4.7 <i>PCIS-ICL: InControl™ Driver</i>	6
1.4.8 <i>PCIS-OPC: OPC Server</i>	7
Installation	8
2.1 What You Have	8
2.2 Unpacking.....	9
2.3 PCB Layout.....	10
2.3.1 <i>PCI-7250' PCB Layout</i>	10
2.3.2 <i>cPCI-7252' PCB Layout</i>	11
2.4 Input Signal Jumper Setting	12
2.5 Hardware Installation Outline	13
2.5.1 <i>PCI configuration</i>	13
2.5.2 <i>PCI slot selection</i>	13
2.5.3 <i>Installation Procedures</i>	13
2.6 Device Installation for Windows Systems.....	13
2.7 Connector Pin Assignments	14
2.7.1 <i>PCI-7250/51 Pin assignments</i>	14
2.7.2 <i>cPCI-7252 Pin assignments</i>	15
2.8 PCI-7250 and PCI-7251 Connection	16

Registers.....	17
3.1 PCI PnP Registers.....	17
3.2 I/O Address Map.....	18
3.3 Relay Output and Readback Registers	19
3.4 Isolation Input Registers	19
Operation Theory	20
4.1 Using Relay Output	20
4.2 Using Isolated Input.....	22
C/C++ Libraries.....	24
5.1 Libraries Installation.....	24
5.2 Programming Guide	25
5.2.1 <i>Naming Convention</i>	25
5.2.2 <i>Data Types</i>	25
5.3 Running Testing Utility (7250UTIL.EXE)	26
5.4 725X Initial	27
5.5 _7250_DI, _7252_DI	28
5.6 _7250_DO, _7252_DO	29
5.7 _7250_DO_Read_Back, _7252_DO_ReadRelay	30
5.8 _7251_Check_Exist.....	31
Appendix A.	32
Warranty Policy	35

List of Tables and Figures

Tables

Table 1:	Digital Input Specifications	3
Table 2:	Relay Output Specifications.....	3
Table 3:	General Specifications	4
Table 4:	Power Consumption Specifications	4
Table 5:	Jumpers and DI channels	12
Table 6:	Input Signal Selection Jumper Setting	12
Table 7:	Address map of PCI-7250 with PCI-7251 installed.....	18
Table 8:	Address map of cPCI-7252.....	18

Figures

Figure 1:	PCI-7250 Layout	10
Figure 2:	cPCI-7252 Layout	11
Figure 3:	Pin Assignment of CN1 on the PCI-7250 and PCI-7251	14
Figure 4:	Pin Assignment of CN1 on the cPCI-7252.....	15
Figure 5:	Connection between PCI-7250 and PCI-7251	16
Figure 6:	Form C Relay	20
Figure 7:	Form A Relay	21
Figure 8:	PCI-7250 Isolated Input Circuit	22
Figure 9:	cPCI-7252 Differential Input Circuit.....	22

How to Use This Guide

This manual is intended to assist users to configure the PCI-7250, PCI-7251 and cPCI7252 Relay Actuator & Isolated D/I Cards. For convenient purposes the above models will be referred to as PCI-725X. This guide is divided into 5 chapters.

- Chapter 1, “Introduction”**, gives an overview of the product features, applications, and specifications.
- Chapter 2, “Installation”**, describes how to install the PCI-725X. The layout of PCI-725X is shown. Jumper setting for Input Signal Configuration and how to connect external signals are also described.
- Chapter 3, “Programming”**, describes how to program the digital input and output channels on the PCI-725X.
- Chapter 4, “Relay Outputs & Isolation Inputs”**, gives an overview of the PCI-725X's relay outputs and isolation inputs.
- Chapter 5, “C/C++ Libraries”**, describes the DOS and Windows 95 C/C++ Library for operating the PCI-725X.



Introduction

The PCI-7250/7251 and cPCI-7252 Relay Actuator and Isolated D/I card is a basic Digital I/O card for PCI bus compliant computers used in industrial applications.

This PCI-7250 and PCI-7251 provides 8 relay actuators and 8 opto-isolated digital inputs. Of the eight relays, four are Form C (R0~R3) and four are Form A (R4~R7). The cPCI-7252 provides 8 relay actuators and 16 opto-isolated digital inputs; all relays are of Form C type. They are very suited for constant ON/OFF control devices.

All channels are isolated and suitable for collecting digital input signals in a noisy environment. For identical non-polarized opto-isolated digital input channels, switching can be carried out using AC-filtered or non-AC-filtered channels.

A LED reflects the status of each relay output. When a relay is energized, its corresponding LED will turn ON, otherwise it is OFF.

The relay outputs and digital inputs are controlled by two bytes of I/O addresses. When a bit is read or written, its output status will be controlled, or it's input status will be monitored. The I/O signals are routed through to a 37-pin D-type connector that protrudes through the computer case at the rear.

1.1 Features

The PCI-725X Relay Actuator and D/I Card provides the following advanced features:

- 32-bit PCI-Bus, Plug and Play for PCI-7250
- 32-bit CompactPCI® Bus, Plug and Play for cPCI-7252
- 8 relay actuator outputs
- 8 opto-isolated digital inputs for PCI-7250
- 16 opto-isolated digital inputs for cPCI-7252
- LED indicators to show energized relays
- Jumper selectable AC-filter/non-AC-filter input signals
- On-board relay driving circuits
- On-board digital input signal conditioning circuits

Note: The PCI-7251 attaches to the PCI-7250 card. Each PCI-7251 card attached provides an additional 8 relay output and 8 photo isolated input signals. There can be at most three PCI-7251 cards that can be attached to one PCI-7250 card; hence the system can provide 32 relay output signals and 32 photo isolated inputs signals.

1.2 Applications

- Industrial ON/OFF control
- External high power relay driving signal switching
- Laboratory automation
- Industrial automation
- Switch contact status sensing, limit switch monitoring,
- Useful with A/D and D/A cards to implement a data acquisition & control system

1.3 Specifications

1.3.1 Digital input

Input channels	8 for PCI-7250 and PCI-7251 16 for cPCI-7252
Photo-coupler	PC-814
Input current	10 mA rated 60 mA max for isolated input
Input Voltage	Up-to 24 V _{DC} or 24V _{AC} 50-1,000Hz) Logic Low: 0~2.4V Logic High 3~24V
Threshold Voltage	2.4 VDC
Input impedance	1.2 K Ω
Input mode	Isolation AC-filter/ Non-AC-filter
Isolated voltage	5,000 Vrms channel-to-system

Table 1: Digital Input Specifications

1.3.2 Relay Output

Output channels	8
Relay type	4 SPDT (Form C) 4 SPST (Form A)
Contact rating	120V _{AC/DC} , 0.5 A 24V _{DC} , 1A
Breakdown voltage	1000 V AC/DC min..
Release time	8 msec typical
Operate time	8 msec typical
Contact resistance	Bifurcated
Insulation resistance	100M Ω min.
Life expectancy	> 10 million operations at full load
LED indicators	Monitor ON/OFF status of each relay
Coil Voltage	+5V, 33 mA for each relay, total 0.264 A
Power supply of Relay	+ 5V from the PCI-Bus

Table 2: Relay Output Specifications

1.3.3 General Specifications

Dimension	<ul style="list-style-type: none">• 162 mm x 107 mm for PCI-7250• 141 mm x 102 mm for PCI-7251• 160 mm x 100 mm for cPCI-7252
Bus	32-bit PCI bus
Operating temperature	0 ~ 60 °C (Operating);
Storage temperature	-20 °C ~ 80 °C (Operating);
Humidity	5 to 90% non-condensing

Table 3: General Specifications

1.3.4 Power Consumption

Power Consumption	Note: No relay is energized
PCI-7250	+5V @ 140 mA
PCI-7251	+5V @ 125 mA
cPCI-7252	+5V @ 120 mA

Table 4: Power Consumption Specifications

1.4 Software Supporting

ADLINK provides versatile software drivers and packages for users' different approach to building a system. We not only provide programming libraries such as DLL for many Windows systems, but also provide drivers for many software package such as LabVIEW[®], HP VEE[™], DASyLab[™], InTouch[™], InControl[™], ISaGRAF[™], and so on.

All software options are included in the ADLINK CD. Non-free software drivers are protected with licensing codes. Without the software code, you can install and run the demo version for two hours for trial/demonstration purposes. Please contact ADLINK dealers to purchase the formal license.

1.4.1 Programming Library

For customers who are writing their own programs, we provide function libraries for many different operating systems, including:

- DOS Library: Borland C/C++ and Microsoft C++, the functions descriptions are included in this user's guide.
- Windows 95 DLL: For VB, VC++, Delphi, BC5, the functions descriptions are included in this user's guide.
- PCIS-DASK: Include device drivers and DLL for Windows 98, Windows NT and Windows 2000. DLL is binary compatible across Windows 98, Windows NT and Windows 2000. That means all applications developed with PCIS-DASK are compatible across Windows 98, Windows NT and Windows 2000. The developing environment can be VB, VC++, Delphi, BC5, or any Windows programming language that allows calls to a DLL. The user's guide and function reference manual of PCIS-DASK are in the CD. Please refer the PDF manual files under \\Manual_PDF\Software\PCIS-DASK

The above software drivers are shipped with the board. Please refer to the "Software Installation Guide" for installation procedures.

1.4.2 PCIS-LVIEW: LabVIEW® Driver

PCIS-LVIEW contains the VIs, which are used to interface with NI's LabVIEW® software package. The PCIS-LVIEW supports Windows 95/98/NT/2000. The LabVIEW® drivers is shipped free with the board. You can install and use them without a license. For more information about PCIS-LVIEW, please refer to the user's guide in the CD. (\\Manual_PDF\Software\PCIS-LVIEW)

1.4.3 PCIS-VEE: HP-VEE Driver

The PCIS-VEE includes user objects, which are used to interface with the HP VEE software package. PCIS-VEE supports Windows 95/98/NT. The HP-VEE drivers are shipped free with the board. For more information about PCIS-VEE, please refer to the user's guide in the CD. (\\Manual_PDF\Software\PCIS-VEE)

1.4.4 DAQBench™: ActiveX Controls

We suggest customers who are familiar with ActiveX controls and VB/VC++ programming use the DAQBench™ ActiveX Control component library for developing applications. The DAQBench™ is designed under Windows NT/98. For more information about DAQBench, please refer to the user's guide in the CD. (\\Manual_PDF\Software\DAQBench\DAQBench Manual.PDF).

1.4.5 PCIS-DDE: DDE Server and InTouch™

DDE stands for Dynamic Data Exchange. The PCIS-DDE includes the PCI cards' DDE server. The PCIS-DDE server is included in the ADLINK CD. It needs a license. The DDE server can be used in conjunction with any DDE client under Windows NT.

1.4.6 PCIS-ISG: ISaGRAF™ driver

The ISaGRAF WorkBench is an IEC1131-3 SoftPLC control program development environment. The PCIS-ISG includes ADLINK product drivers for ISaGRAF under Windows NT environment. The PCIS-ISG is included in the ADLINK CD. A license is needed to use the drivers.

1.4.7 PCIS-ICL: InControl™ Driver

PCIS-ICL is the InControl driver, which supports Windows NT. The PCIS-ICL is included in the ADLINK CD. A license is needed to use the drivers.

1.4.8 PCIS-OPC: OPC Server

PCIS-OPC is an OPC Server, which can link with OPC clients. There are several software packages on the market, which can provide the OPC clients. The PCIS-OPC supports Windows NT and requires a license to operate.

2

Installation

This chapter describes how to install and setup the 725X cards. The contents in the package and unpacking information that you should be aware of are outlined first. The jumper settings for the digital input channel configuration (AC-filter or Non-AC-filter) and the signal definitions of the 37-pins connectors are also specified in this chapter.

2.1 What You Have

In addition to this *User's Manual*, the package should includes the following items:

- PCI-7250 (or PCI-7251, cPCI-7252) Relay Actuator & Isolated D/I Card
- ADLINK CD (for PCI-7250 and cPCI-7252 only)
- Software Installation Guide

If any of these items are missing or damaged, contact ADLINK or the dealer from whom you purchased the product. Save the shipping materials and carton in case you want to ship or store the product in the future.

2.2 Unpacking

The PCI-725X card contains electro-static sensitive components that can be easily be damaged by static electricity.

Therefore, the card should be handled on a grounded anti-static mat. The operator should be wearing an anti-static wristband, grounded at the same point as the anti-static mat.

Inspect the card module carton for obvious damages. Shipping and handling may cause damage to your module. Be sure there are no shipping and handling damages on the modules carton before continuing.

After opening the card module carton, extract the system module and place it only on a grounded anti-static surface with component side up.

Again, inspect the module for damages. Press down on all the socketed IC's to make sure that they are properly seated. Do this only with the module place on a firm flat surface.

Note: DO NOT APPLY POWER TO THE CARD IF IT HAS BEEN DAMAGED.

You are now ready to install your 7250 series products.

2.3 PCB Layout

2.3.1 PCI-7250' PCB Layout

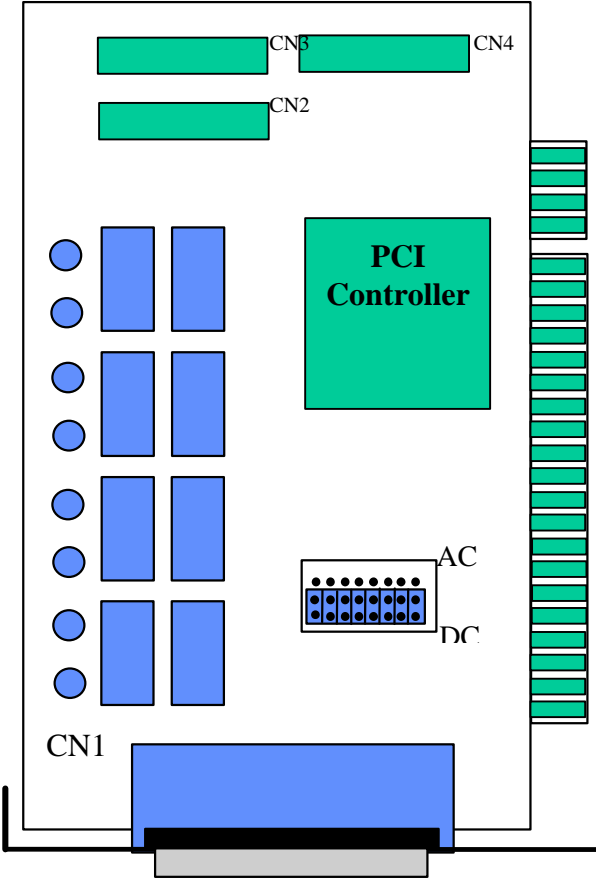

Figure 1: PCI-7250 Layout

2.3.2 cPCI-7252' PCB Layout

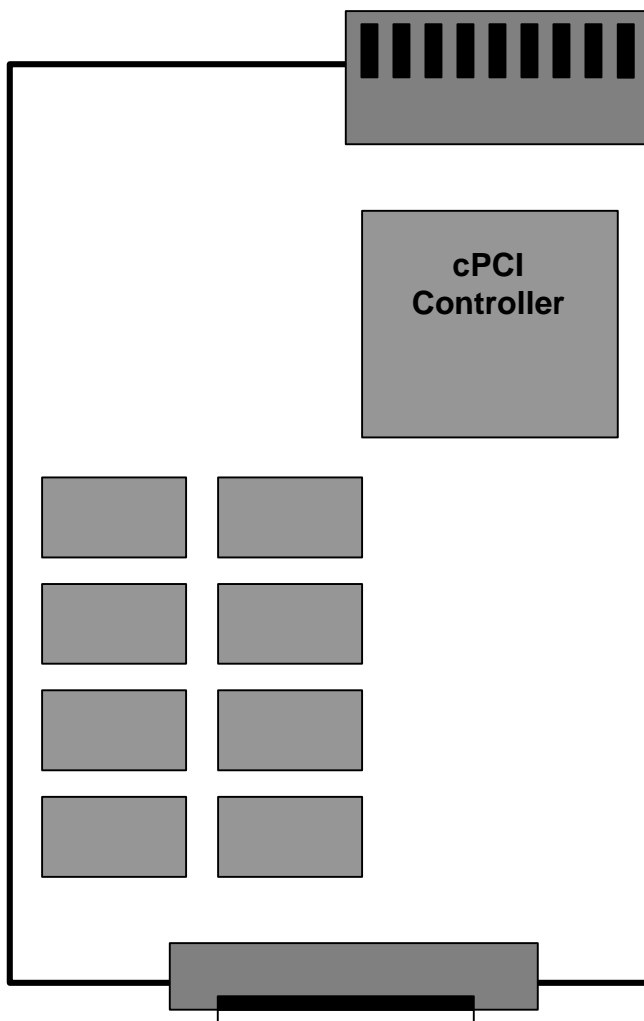

Figure 2: cPCI-7252 Layout

2.4 Input Signal Jumper Setting

Note: This section is for PCI-7250 and PCI-7251 only.

With the PCI-7250 and PCI-7251, there are 8 jumpers (JP1 to JP8); each one is associated with one digital input for configuring the channel as either *AC-Filtered* or *Non-AC-Filtered*. The digital input channel and their corresponding jumper are listed in the table below

JUMPER	INPUT SIGNAL
JP1	DI0
JP2	DI1
JP3	DI2
JP4	DI3
JP5	DI4
JP6	DI5
JP7	DI6
JP8	DI7

Table 5: Jumpers and DI channels

The default setting for the input signal selection is **Non-AC-Filter** (DC signal input), which is shown as below:

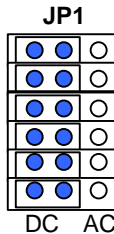

Input Signal Selection	Non-AC-Filter (DC Signal)	AC-Filter (AC Signal)
Jumper JP1 ~ JP8	2-3	1-2

Table 6: Input Signal Selection Jumper Setting

2.5 Hardware Installation Outline

2.5.1 PCI configuration

The PCI cards (or CompactPCI cards) are equipped with plug and play PCI controllers, it can request base addresses and interrupts according to the PCI standard. The system BIOS will assign the system resources based on the PCI cards' configuration registers and system parameters (which are set by the system BIOS). Interrupt assignment and memory usage (I/O port locations) can only be assigned by the system BIOS. These system resource assignments are done on a board-by-board basis. It is not suggested to assign the system resource by any other methods.

2.5.2 PCI slot selection

The PCI card can be inserted into any PCI slot without any configuration of the system resources. The CompactPCI card can also be inserted into any CompactPCI I/O slot.

2.5.3 Installation Procedures

1. Turn off your computer
2. Turn off all accessories (printer, modem, monitor, etc.) connected to your computer.
3. Remove the cover from your computer.
4. Setup jumpers on the PCI or CompactPCI card.
5. Select a 32-bit PCI slot. PCI slot are shorter than ISA or EISA slots, and are usually white or ivory.
6. Before handling the PCI cards, discharge any static buildup on your body by touching the metal case of the computer. Hold the edge and do not touch the components.
7. Position the board into the PCI slot you selected.
8. Secure the card in place at the rear panel of the system.

2.6 Device Installation for Windows Systems

Once Windows 95/98/2000 has started, the Plug and Play functions of the Windows system will find and locate the new NuDAQ/NuIPC card. If this is the first time a NuDAQ/NuIPC card is installed in your Windows system, you will be prompted to input the device information source. Please refer to the **“Software Installation Guide”** for installation procedures for the device drivers.

2.7 Connector Pin Assignments

2.7.1 PCI-7250/51 Pin assignments

The PCI-7250 card comes equipped with a 37-pin D type connector (CN1) accessible from the rear of the card (Ref. Fig 1). The pin assignment of the D type connector is shown in Figure 3.

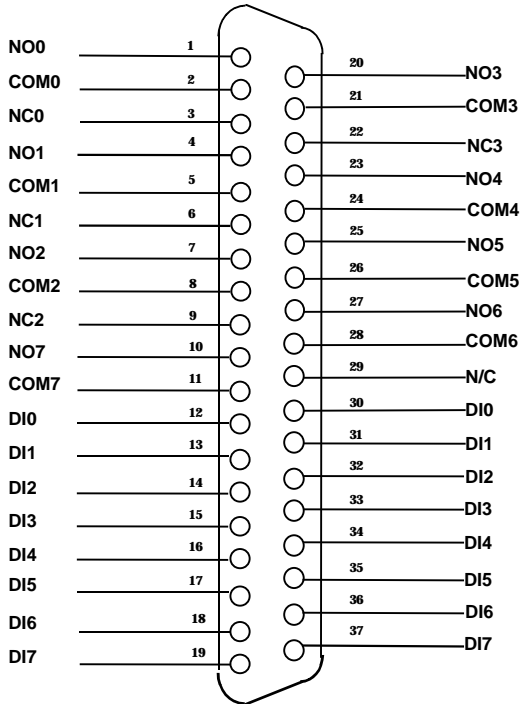

Figure 3: Pin Assignment of CN1 on the PCI-7250 and PCI-7251

Legend:

- Din: digital input low, channel n (input signal is not polarity sensitive)
- NC n: normal close pin of relay n
- NO n: normal open pin of relay n
- COM n: common pin of relay n
- N/C: No Connection

2.7.2 cPCI-7252 Pin assignments

IGND	1	26	IGND
DI8	2	27	DI12
DI9	3	28	DI13
DI10	4	29	DI14
DI11	5	30	DI15
DI0L	6	31	DI4L
DI0H	7	32	DI4H
DI1L	8	33	DI5L
DI1H	9	34	DI5H
D2IL	10	35	DI6L
DI2H	11	36	DI6H
DI3L	12	37	DI7L
DI3H	13	38	DI7H
NO0	14	39	NO5
NO1	15	40	NO4
COM0	16	41	COM5
COM1	17	42	COM4
NC0	18	43	NC5
NC1	19	44	NC4
NC2	20	45	NO7
NO3	21	46	NO6
COM2	22	47	COM7
COM3	23	48	COM6
NC2	24	49	NC7
NC3	25	50	NC6

Figure 4: Pin Assignment of CN1 on the cPCI-7252

Legend:

- Din: digital input channel n
- IGND: ground of DI n signals
- DinH: digital input channel n with positive polarity
- DinL: digital input channel n with negative polarity
- NC n: normal close pin of relay n
- NO n: normal open pin of relay n
- COM n: common pin of relay n

2.8 PCI-7250 and PCI-7251 Connection

There are 8-relay outputs and 8-isolation inputs on both the PCI-7250 and PCI-7251. The PCI-7251 is used as an expansion for the PCI-7250. The operations of the PCI-7251 are the same as that of the PCI-7250. There are at most 3 PCI-7251 expansion boards to one PCI-7250. Therefore, the PCI-7250 can control up to 32 relays and detect 32 input signals. Figure 5 shows a block diagram of connecting the PCI-7250 and PCI-7251.

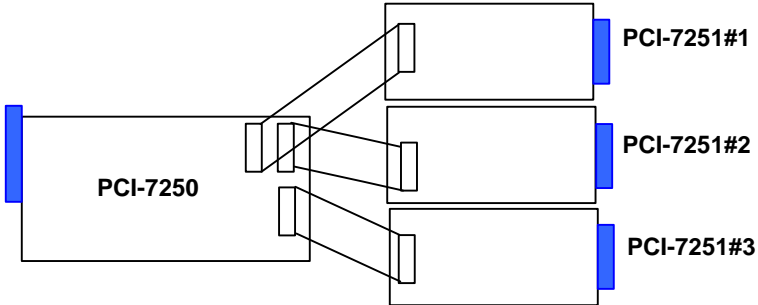

Figure 5: Connection between PCI-7250 and PCI-7251

3

Registers

Detailed descriptions of the registers are specified in this chapter. This information is useful for programmers who wish to handle the card with low-level programming. However, we suggest users to an understanding of the PCI interface before starting any low-level programming. In addition, the contents of this chapter will also help users understand how to use the software drivers to configure this card.

3.1 PCI PnP Registers

This PCI card functions as a 32-bit PCI target device to any master on the PCI bus. There are three types of registers: PCI Configuration Registers (PCR), Local Configuration Registers (LCR) and 725X registers.

The PCR, which is PCI-bus specifications compliant, is initialized and controlled by the plug & play (PnP) PCI BIOS. Users may obtain more information on the PCI BIOS specification to better understand the operation of the PCR. Please contact PCISIG to acquire the specifications of the PCI interface.

The PCI bus controller PCI-9050 is provided by PLX technology Inc. (www.plxtech.com). For more information about the LCR, please visit PLX technology's web site to download relative information. It is not necessary for users to fully understand the details of the LCR if the software library provided is used. The PCI PnP BIOS assigns the base address of the LCR. The assigned address is located at an offset of 14h from the PCR.

The 725X registers are discussed in the next section. The base address, which is also assigned by the PCI PnP BIOS, is located at an offset of 18h from the PCR. Therefore, users can read the address 18h from the PCR to obtain its base address by using the BIOS function call. Do not attempt to modify the base address and interrupt that have been assigned by the PCI PnP BIOS, it may cause resource conflicts with your system.

3.2 I/O Address Map

All 725X registers are 8 bits long. Users can access these registers using 8-bit I/O instructions. Using these registers will allow the relays and status of the inputs to be controlled. The following table shows the registers address map, including descriptions and their offset addresses relative to the base address. If the PCI-7251 expansion boards are not installed, corresponding registers have no significant.

Offset	Write	Read	Board
0	Relay Output	Output readback	PCI-7250
1	Not used	Isolation Input	
2	Relay Output	Output readback	PCI-7251 #1
3	Not used	Isolation Input	
4	Relay Output	Output readback	PCI-7251 #2
5	Not used	Isolation Input	
6	Relay Output	Output readback	PCI-7251 #3
7	Not used	Isolation Input	

Table 7: Address map of PCI-7250 with PCI-7251 installed

Offset	Write	Read	Board
0	Relay Output	Isolation Input	cPCI-7252
1	Not used	Not used	
2	Not used	Output readback	

Table 8: Address map of cPCI-7252

3.3 Relay Output and Readback Registers

There are 8 relays on each PCI-7250 / 7251 and cPCI-7252 board. Each relay is controlled by one bit in the control register. Bit value '0' means the relay is not energized. The normal open signal line is 'open'. Bit value '1' means the relay is energized and the normal open signal line is now closed.

The initial bit values of the control register are all '0' and the status of the relay can be readback from the readback register. If the relay is open, the corresponding bit value read is '0'. If the relay is closed, the bit value read is '1'.

Data Format of Relay Output and Readback Status Registers:

Bit	7	6	5	4	3	2	1	0
Relay Output	DO7	DO6	DO5	DO4	DO3	DO2	DO1	DO0
Output Readback	RB7	RB6	RB5	RB4	RB3	RB2	RB1	RB0

3.4 Isolation Input Registers

There are 8 isolated input channels on the PCI-7250 / 7251 board. The status of the 8 channels can be read from the isolation input register. Each bit corresponds to each channel. Bit value "1" means input voltage is high and "0" means input voltage is low.

Data Format:

Relay Output:

Bit	7	6	5	4	3	2	1	0
Iso. Input	DI7	DI6	DI5	DI4	DI3	DI2	DI1	DI0
Bit	15	14	13	12	11	10	9	8
Iso. Input	DI15	DI14	DI13	DI12	DI11	DI10	DI9	DI8

Note: bit#8~15 is for cPCI-7252 only

4

Operation Theory

4.1 Using Relay Output

The PCI-7250 contains two types of relays: Form C and Form A. Relays R0 ~ R3 are form C relays, and R4 ~ R7 are plain form A type. Note that the cPCI-7252 contains Form C relays only. The differences between these two types of relays are:

1. Form C Relay: (R0 ~ R3)

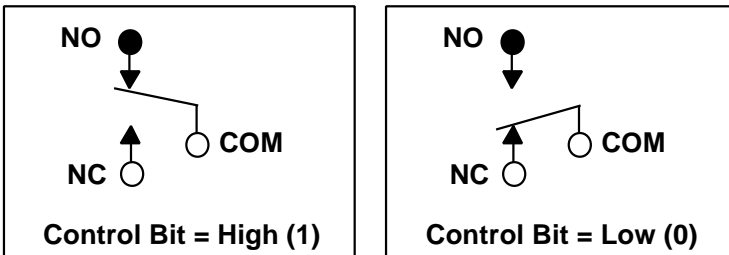

Figure 6: Form C Relay

Form C type relays have three contacts: NC (Normal Close), NO (Normal Open), and COM (Common). The COM post, located at the middle, must make contact with either the NO post or NC post. When the control bit is high (1), there is contact between the COM post and NO post. If the control bit is low (0), there is contact between the COM post and NC post.

In normal power-up and reset, the relay is in **low** status.

2. Form A Relay: (R4 ~ R7)

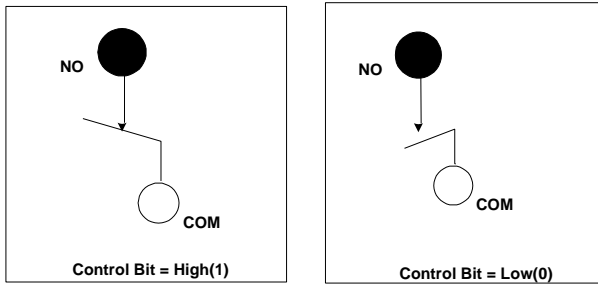

Figure 7: Form A Relay

Form A relay only has two contacts: NO (Normal Open) and COM (Common). The COM post can make contact either with the NO post or not. When the control bit is high (1), the COM post and NO post are contacted. If the control bit is low (0), the COM post and NO post does not make contact.

In normal power-up and reset, the relay is in **low** status.

The relay output contacts are rated at a maximum of 0.5A at 120VAC (resistive), 1A 24VDC, or 0.3A 60VDC. You should reduce these ratings for inductive loads. For more information on relay contact, please refer to Appendix A.

4.2 Using Isolated Input

The PCI-7250 (or PCI-7251) contains 8 identical opto-isolated control input channels. The circuit diagram of the isolated input channel is shown below.

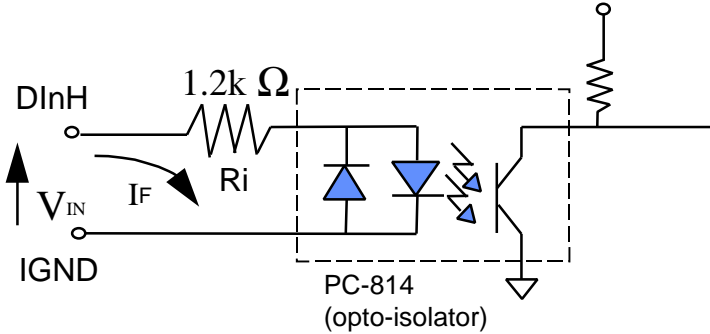

Figure 8: PCI-7250 Isolated Input Circuit

The digital input is first routed through a photo-coupler (PC-814), so that the connection is not polarity sensitive whether AC or DC voltage is used. The cPCI-7252 contains 16 identical opto-isolated control input channels. The circuit diagram of the isolated input signals of channel number 8~15 are the same as of the PCI-7250. While, the input signals for channel numbers 0~7 are differential inputs, which is shown in the following diagram.

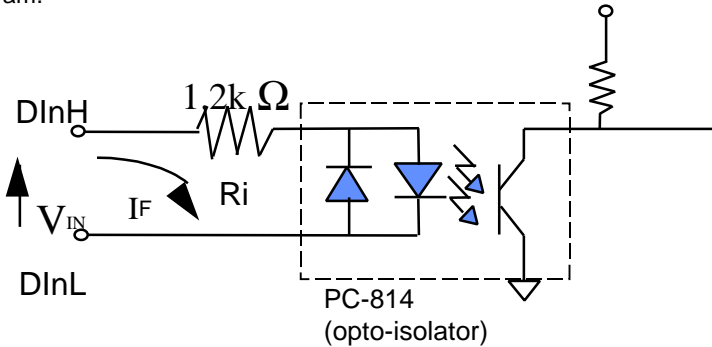

Figure 9: cPCI-7252 Differential Input Circuit

In addition, a single-pole filter with a time constant of about 5ms is used to filter AC inputs passing through.

The normal input voltage range for an active high state is 3 to 24VAC or DC. The normal input range can be extended by changing the resistor (Ri) to limit the current (IF) through the PC-814 (opto-isolator to about 10mA). The exact resistor value to replace the original resistor Ri (1.2K Ω) can be calculated by the following formula.

$$\mathbf{V_{in} = I_F \times R_i}$$

$$\mathbf{P_w = V_{in} \times I_F}$$

For example, if the input voltage is 110V, then the Ri should be replaced by

$$R_i = 110 \text{ (V)} / 0.01 \text{ (A)} = 11 \text{ K}\Omega$$

$$P_w = 110 \text{ (V)} \times 0.01 \text{ (A)} = 1.1 \text{ W}$$

5

C/C++ Libraries

This chapter describes the software libraries for operating this card. Only the functions in the DOS library and Windows 95 DLL are described. Refer to the PCIS-DASK function reference manual, which is included in the ADLINK CD, for descriptions of Windows 98/NT/2000 DLL functions.

The function prototypes and useful constants are defined in the header files located in the LIB directory (DOS) and INCLUDE directory (Windows 95). For Windows 95 DLL, the developing environment can be Visual Basic 4.0 or above, Visual C/C++ 4.0 or above, Borland C++ 5.0 or above, Borland Delphi 2.x (32-bit) or above, or any Windows programming language that allows calls to a DLL.

5.1 Libraries Installation

Refer to the “Software Installation Guide” for information regarding software installation of libraries for DOS, Windows 95 DLL, or PCIS-DASK for Windows 98/NT/2000.

The device drivers and DLL functions for Windows 98/NT/2000 are included in the PCIS-DASK. Refer to the PCIS-DASK user’s guide and function reference, which is included in the ADLINK CD, for programming information.

5.2 Programming Guide

5.2.1 Naming Convention

The functions of the NuDAQ PCI or NuIPC CompactPCI card software drivers uses full-names to represent the functions' real meaning. The naming convention rules are:

In DOS Environment:

`_{hardware_model}_{action_name}`. e.g. `_7250_Initial()`.

All functions in the PCI-7250 driver start with 7250 as `{hardware_model}`. All functions in cPCI-7252 driver start with 7252 as `{hardware_model}`.

In order to recognize the difference between the DOS library and Windows 95 library, a capital "W" is placed at the start of each function name for Windows 95 DLL drivers. e.g. `W_7252_Initial()`.

5.2.2 Data Types

We have defined some data types in the `Pci_7250.h` (DOS) and `Acl_pci.h` (Windows 95) header files. These data types are used by the NuDAQ Cards' library. We recommend you use these data types in your application programs. The following table shows the data type names and their range.

Type Name	Description	Range
U8	8-bit ASCII character	0 to 255
I16	16-bit signed integer	-32768 to 32767
U16	16-bit unsigned integer	0 to 65535
I32	32-bit signed integer	-2147483648 to 2147483647
U32	32-bit single-precision floating-point	0 to 4294967295
F32	32-bit single-precision floating-point	-3.402823E38 to 3.402823E38
F64	64-bit double-precision floating-point	-1.797683134862315E308 to 1.797683134862315E309
Boolean	Boolean logic value	TRUE, FALSE

5.3 Running Testing Utility (7250UTIL.EXE)

After finishing the DOS installation, you can execute the utility by typing the following command:

The following:

```
C> cd\ADLINK\7252\DOS\UTIL
```

(Or "cd\ADLINK\7250\DOS\util" for PCI-7250).

```
C> 7252UTIL
```

The following interface will be displayed on the screen.

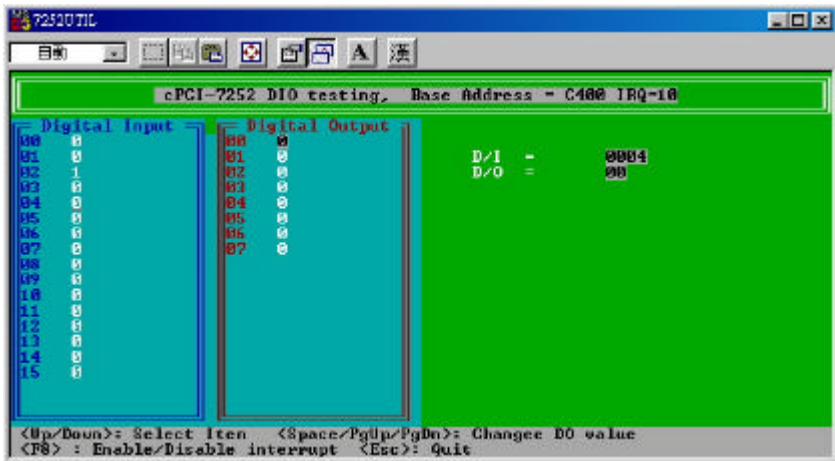

You can use this program to test the functionality of the digital inputs and outputs.

A detailed description of each function is specified in the preceding sections.

5.4 725X Initial

@ Description

The PCI-7250 and cPCI-7252 cards are initialized according to the card number. Because the PCI-7250 has a PCI bus architecture and meets the plug and play design specification, the **IRQ** and **base_address** (pass-through address) are assigned by the system BIOS directly. Every PCI-7250 card has to be initialized by this function before calling any other functions.

Note: Because the configuration of PCI card is handled by the system, there are no jumpers or IRQ selection on the PCI board that needs to be set up by the users.

@ Syntax

C/C++ (DOS)

```
U16  _7250_Initial  (U16  *existCards,  PCI_INFO
                    *pciInfo)
U16  _7252_Initial  (U16  *existCards,  PCI_INFO
                    *pciInfo)
```

C/C++ (Windows 95)

```
U16  W_7250_Initial (U16  *existCards,  PCI_INFO
                    *pciInfo)
U16  W_7252_Initial (U16  *existCards,  PCI_INFO
                    *pciInfo)
```

Visual Basic (Windows 95)

```
W_7250_Initial (existCards As Integer, pciInfo
                As PCI_INFO) As Integer
W_7252_Initial (existCards As Integer, pciInfo
                As PCI_INFO) As Integer
```

@ Argument

existCards: The number of installed PCI-7250 cards. The returned value shows how many PCI-7250 cards are installed in your system.

pciinfo: It is a structure to memorize the PCI bus plug and play initialization information, which is decided by the P&P BIOS. The PCI_INFO structure is defined in ACL_PCI.H. The base I/O addresses and the interrupt channel number are stored in pciinfo, which is for reference.

@ Return Code

```
ERR_NoError, ERR_PCIBiosNotExist
```

5.5 `_7250_DI`, `_7252_DI`

@ *Description*

This function is used to read data from the digital input port. There are eight 8-bit digital inputs on the PCI-7250 or PCI-7251 extended board. You can obtain all 32 input data from using the `_7250_DI` function.

@ *Syntax*

C/C++ (DOS)

```
U16 _7250_DI (U16 cardNo, U16 diPortNo, U16 *diData)
```

```
U16 _7252_DI (U16 cardNo, U16 *diData)
```

C/C++ (Windows 95)

```
U16 W_7250_DI (U16 cardNo, U16 diPortNo, U16 *diData)
```

```
U16 W_7252_DI (U16 cardNo, U16 *diData)
```

Visual Basic (Windows 95)

```
W_7250_DI (ByVal cardNo As Integer, ByVal diPortNo As Integer, diData As Integer) As Integer
```

```
W_7252_DI (ByVal cardNo As Integer, diData As Integer) As Integer
```

@ *Argument*

cardNo: card number selected

diPortNo: Digital Input Channel No, the constant is

Note: This argument is not necessary for `cPCI-7252`.

`DI_PORT0` 0x00 Access the 8 Digital Input of PCI-7250

`DI_PORT1` 0x01 Access the 8 Digital Input of Expansion Board PCI-7251#1

`DI_PORT2` 0x02 Access the 8 Digital Input of Expansion Board PCI-7251#2

`DI_PORT3` 0x03 Access the 8 Digital Input of Expansion Board PCI-7251#3

diData: return 8-bit value from digital port.

@ *Return Code*

`ERR_NoError`

`ERR_BoardNoInit`

5.6 `_7250_DO`, `_7252_DO`

@ Description

This function is used to write data to the digital output port. This energizes or de-energizes the RELAY. There are 8 digital outputs on the PCI-7250 or PCI-7251 extended board. You can control all 32 RELAY's through using the `_7250_DO` function.

@ Syntax

C/C++ (DOS)

```
U16 _7250_DO (U16 cardNo, U16 doPortNo, U16 doData)
```

```
U16 _7252_DO (U16 cardNo, U16 doData)
```

C/C++ (Windows 95)

```
U16 W_7250_DO (U16 cardNo, U16 doPortNo, U16 doData)
```

```
U16 W_7252_DO (U16 cardNo, U16 doData)
```

Visual Basic (Windows 95)

```
W_7250_DO (ByVal cardNo As Integer, ByVal doPortNo As Integer, ByVal doData As Integer) As Integer
```

```
W_7252_DO (ByVal cardNo As Integer, ByVal doData As Integer) As Integer
```

@ Argument

cardNo: card number selected

doChannelNo: Digital Output Channel No, the constant is

Note: This argument is not necessary for cPCI-7252.

```
DI_PORT0 0x00 Access the 8 Digital Input of PCI-7250
```

```
DI_PORT1 0x01 Access the 8 Digital Input of Expansion Board PCI-7251#1
```

```
DI_PORT2 0x02 Access the 8 Digital Input of Expansion Board PCI-7251#2
```

```
DI_PORT3 0x03 Access the 8 Digital Input of Expansion Board PCI-7251#3
```

doData: value will be written to digital output port

@ Return Code

```
ERR_NoError, ERR_BoardNoInit
```

5.7 `_7250_DO_Read_Back`, `_7252_DO_ReadRelay`

@ Description

This function is used to read-back data from the digital output port which is control by the 725X_DO function. There are 8-bit digital outputs on the PCI-7250, cPCI-7252, or PCI-7251 extended board. You can readback all RELAY status (High or Low) by using this function.

@ Syntax

C/C++ (DOS)

```
U16  _7250_DO_Read_Back  (U16  cardNo,    U16
                          doChannelNo, U8  *doReadBackData)
U16  _7252_DO_ReadRelay (U16  cardNo,    U16
                          doReadBackData)
```

C/C++ (Windows 95)

```
U16  W_7250_DO_Read_Back (U16  cardNo,    U16
                          doChannelNo, U16  *doReadBackData)
U16  W_7252_DO_ReadRelay (U16  cardNo,    U16
                          *doReadBackData)
```

Visual Basic (Windows 95)

```
W_7250_DO_Read_Back (ByVal cardNo As Integer,
                     ByVal doChannelNo As Integer, doReadBackData
                     As Integer) As Integer
W_7252_DO_ReadRelay (ByVal cardNo As Integer,
                     doReadBackData As Integer) As Integer
```

@ Argument

cardNo: card number selected
doChannelNo: Digital Output Channel No, the constant is

Note: This argument is not necessary for cPCI-7252.

```
DI_PORT0  0x00  Access the 8 Digital Input of
              PCI-7250
DI_PORT1  0x01  Access the 8 Digital Input of
              Expansion Board PCI-7251#1
DI_PORT2  0x02  Access the 8 Digital Input of
              Expansion Board PCI-7251#2
DI_PORT3  0x03  Access the 8 Digital Input of
              Expansion Board PCI-7251#3
diReadBackData: value read back from digital
                  output port
```

@ Return Code

```
ERR_NoError, ERR_BoardNoInit
```

5.8 _7251_Check_Exist

@ Description

This function is used to check the existence of the PCI-7251 expanded board. For normal configuration, each PCI-7250 can be connected with up to three PCI-7251 boards. This function is used to detect the presence of the PCI-7251.

@ Syntax

C/C++ (DOS)

```
U16 _7251_Check_Exist  
    (U16 cardNo, U16 extnesionBoardNo)
```

C/C++ (Windows 95)

```
U16 _7251_Check_Exist  
    (U16 cardNo, U16 extnesionBoardNo)
```

Visual Basic (Windows 95)

```
W_7251_Check_Exist (ByVal cardNo As Integer,  
    ByVal extensionBoardNo As Integer) As  
    Integer
```

@ Argument

cardNo: card number to select borad

existBoardNo: Extension PCI-7251 No.

PCI_7251_EX1 0x01 PCI-7251 Board #1

PCI_7251_EX2 0x02 PCI-7251 Board #2

PCI_7251_EX3 0x03 PCI-7251 Board #3

@ Return Code

```
PCI_7251_EXIST            1  
PCI_7251_NOT_EXIST       0
```

Appendix A.

Relay Contact Protection Circuits

The contacts are the most important elements of a relay construction, Contact performance conspicuously influenced by contact material, and voltage and current values applied to the contacts.

Other important issue is contact protection; the right contact protection circuit can suppress the counter EMF to a low level. However, note that incorrect use will result in an adverse effect. Typical contact protection circuits are given below:

1. RC Circuit

This circuit is suitable for DC application. If the load is a timer, leakage current flow through the RC circuit may cause faulty operation.

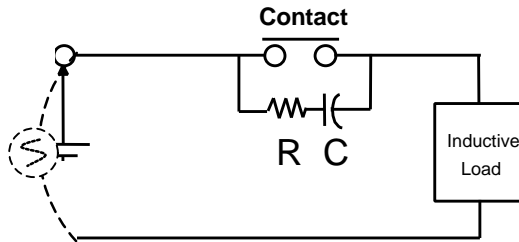

The circuit below is suitable for both DC and AC applications. If the load is a relay or solenoid, the release time is lengthened. Effective when connected to both contacts if the power supply voltage is 24V or 48V and the voltage cross the load is 100 to 200V.

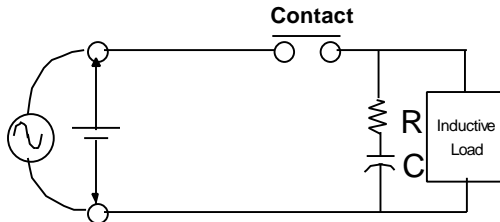

Device Selection:

As a guide in selecting R and C,

R: 0.5 to 1 Ω per 1V contact voltage

C: 0.5 to 1 μF per 1A contact current

Values vary depending on the properties of the capacitor C acting to suppress the discharge the moment the contacts open. Resistor R acts to limit the current when the power is turned on. Test to confirm. Use a capacitor with a breakdown voltage of 200 to 300V. Use AC type capacitors (non-polarized) for AC circuits.

2. Diode Circuit

This circuit is suitable for DC application. The diode connected in parallel causes the energy stored in the coil to flow to the coil in the form of current and dissipates it as joule heat at the resistive component of the inductive load. This circuit further delay the release time compared to the RC circuit.

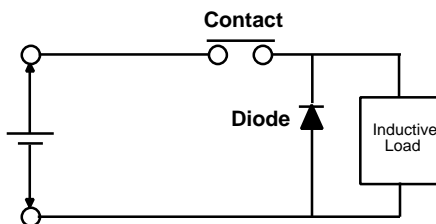

Device Selection:

Use a diode with a reverse breakdown voltage of at least 10 times the circuit voltage and a forward current at least as large as the load current.

3. Diode & Zener diode Circuit

This circuit is also suitable for DC application. Effective when the release time t in the diode circuit is too long.

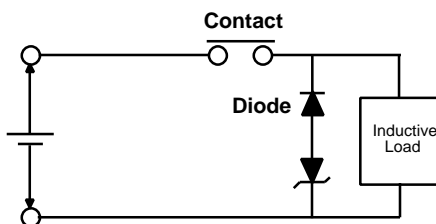

Device Selection:

Use a zener diode with a zener voltage about the same as the power supply voltage.

4. Varistor Circuit

This circuit is also suitable for both AC & DC applications. Using the stable voltage characteristics of the varistor, this circuit prevents excessively high voltages from being applied across the contacts. This circuit also slightly delays the release time. Effective when connected to both contacts if the power supply voltage is 24V or 48V and the voltage cross the load is 100 to 200V.

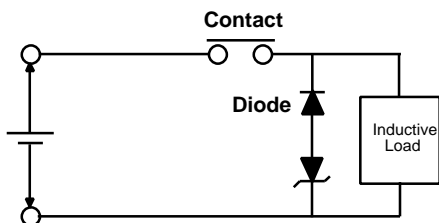

Warranty Policy

Thank you for choosing ADLINK. To understand your rights and enjoy all the after-sales services we offer, please read the following carefully.

1. Before using ADLINK's products, please read the user manual and follow the instructions carefully. When sending in damaged products for repair, please attach an RMA application form.
2. All ADLINK products come with a two-year guarantee, free of repair charge.
 - The warranty period starts from the product's shipment date from ADLINK's factory
 - Peripherals and third-party products not manufactured by ADLINK will be covered by the original manufacturers' warranty
 - End users requiring maintenance services should contact their local dealers. Local warranty conditions will depend on the local dealers
3. Our repair service does not cover the two-year warranty if goods are damaged by the following:
 - a. Damage caused by not following instructions in the user manuals.
 - b. Damage caused by carelessness on the users' part during product transportation.
 - c. Damage caused by fire, earthquakes, floods, lightning, pollution and incorrect usage of voltage transformers.
 - d. Damage caused by unsuitable storage environments with high temperatures, high humidity or volatile chemicals.
 - e. Damage caused by leakage of battery fluid when changing batteries.
 - f. Damages from improper repair by unauthorized technicians.
 - g. Products with altered and damaged serial numbers are not entitled to our service.
 - h. Other categories not protected under our guarantees.
4. Customers are responsible for the fees regarding transportation of damaged products to our company or to the sales office.

5. To ensure the speed and quality of product repair, please download an RMA application form from our company website www.adlinktech.com. Damaged products with RMA forms attached receive priority.

For further questions, please contact our FAE staff.

ADLINK: service@adlinktech.com

Test & Measurement Product Segment: NuDAQ@adlinktech.com

Automation Product Segment: Automation@adlinktech.com

Computer & Communication Product Segment: NuPRO@adlinktech.com;
NuIPC@adlinktech.com

.