

PXI

NI PXI-1045 User Manual

Worldwide Technical Support and Product Information

ni.com

National Instruments Corporate Headquarters

11500 North Mopac Expressway Austin, Texas 78759-3504 USA Tel: 512 683 0100

Worldwide Offices

Australia 1800 300 800, Austria 43 0 662 45 79 90 0, Belgium 32 0 2 757 00 20, Brazil 55 11 3262 3599, Canada 800 433 3488, China 86 21 6555 7838, Czech Republic 420 224 235 774, Denmark 45 45 76 26 00, Finland 385 0 9 725 725 11, France 33 0 1 48 14 24 24, Germany 49 0 89 741 31 30, India 91 80 51190000, Israel 972 0 3 6393737, Italy 39 02 413091, Japan 81 3 5472 2970, Korea 82 02 3451 3400, Lebanon 961 0 1 33 28 28, Malaysia 1800 887710, Mexico 01 800 010 0793, Netherlands 31 0 348 433 466, New Zealand 0800 553 322, Norway 47 0 66 90 76 60, Poland 48 22 3390150, Portugal 351 210 311 210, Russia 7 095 783 68 51, Singapore 1800 226 5886, Slovenia 386 3 425 4200, South Africa 27 0 11 805 8197, Spain 34 91 640 0085, Sweden 46 0 8 587 895 00, Switzerland 41 56 200 51 51, Taiwan 886 02 2377 2222, Thailand 662 278 6777, United Kingdom 44 0 1635 523545

For further support information, refer to the *Technical Support and Professional Services* appendix. To comment on National Instruments documentation, refer to the National Instruments Web site at ni.com/info and enter the info code `feedback`.

Important Information

Warranty

The NI PXI-1045 is warranted against defects in materials and workmanship for a period of one year from the date of shipment, as evidenced by receipts or other documentation. National Instruments will, at its option, repair or replace equipment that proves to be defective during the warranty period. This warranty includes parts and labor.

The media on which you receive National Instruments software are warranted not to fail to execute programming instructions, due to defects in materials and workmanship, for a period of 90 days from date of shipment, as evidenced by receipts or other documentation. National Instruments will, at its option, repair or replace software media that do not execute programming instructions if National Instruments receives notice of such defects during the warranty period. National Instruments does not warrant that the operation of the software shall be uninterrupted or error free.

A Return Material Authorization (RMA) number must be obtained from the factory and clearly marked on the outside of the package before any equipment will be accepted for warranty work. National Instruments will pay the shipping costs of returning to the owner parts which are covered by warranty.

National Instruments believes that the information in this document is accurate. The document has been carefully reviewed for technical accuracy. In the event that technical or typographical errors exist, National Instruments reserves the right to make changes to subsequent editions of this document without prior notice to holders of this edition. The reader should consult National Instruments if errors are suspected. In no event shall National Instruments be liable for any damages arising out of or related to this document or the information contained in it.

EXCEPT AS SPECIFIED HEREIN, NATIONAL INSTRUMENTS MAKES NO WARRANTIES, EXPRESS OR IMPLIED, AND SPECIFICALLY DISCLAIMS ANY WARRANTY OF MERCHANTABILITY OR FITNESS FOR A PARTICULAR PURPOSE. CUSTOMER'S RIGHT TO RECOVER DAMAGES CAUSED BY FAULT OR NEGLIGENCE ON THE PART OF NATIONAL INSTRUMENTS SHALL BE LIMITED TO THE AMOUNT THEREOF PAID BY THE CUSTOMER. NATIONAL INSTRUMENTS WILL NOT BE LIABLE FOR DAMAGES RESULTING FROM LOSS OF DATA, PROFITS, USE OF PRODUCTS, OR INCIDENTAL OR CONSEQUENTIAL DAMAGES, EVEN IF ADVISED OF THE POSSIBILITY THEREOF. This limitation of the liability of National Instruments will apply regardless of the form of action, whether in contract or tort, including negligence. Any action against National Instruments must be brought within one year after the cause of action accrues. National Instruments shall not be liable for any delay in performance due to causes beyond its reasonable control. The warranty provided herein does not cover damages, defects, malfunctions, or service failures caused by owner's failure to follow the National Instruments installation, operation, or maintenance instructions; owner's modification of the product; owner's abuse, misuse, or negligent acts; and power failure or surges, fire, flood, accident, actions of third parties, or other events outside reasonable control.

Copyright

Under the copyright laws, this publication may not be reproduced or transmitted in any form, electronic or mechanical, including photocopying, recording, storing in an information retrieval system, or translating, in whole or in part, without the prior written consent of National Instruments Corporation.

Trademarks

National Instruments, NI, ni.com, and LabVIEW are trademarks of National Instruments Corporation. Refer to the *Terms of Use* section on ni.com/legal for more information about National Instruments trademarks.

Other product and company names mentioned herein are trademarks or trade names of their respective companies.

Members of the National Instruments Alliance Partner Program are business entities independent from National Instruments and have no agency, partnership, or joint-venture relationship with National Instruments.

Patents

For patents covering National Instruments products, refer to the appropriate location: **Help»Patents** in your software, the `patents.txt` file on your CD, or ni.com/patents.

WARNING REGARDING USE OF NATIONAL INSTRUMENTS PRODUCTS

(1) NATIONAL INSTRUMENTS PRODUCTS ARE NOT DESIGNED WITH COMPONENTS AND TESTING FOR A LEVEL OF RELIABILITY SUITABLE FOR USE IN OR IN CONNECTION WITH SURGICAL IMPLANTS OR AS CRITICAL COMPONENTS IN ANY LIFE SUPPORT SYSTEMS WHOSE FAILURE TO PERFORM CAN REASONABLY BE EXPECTED TO CAUSE SIGNIFICANT INJURY TO A HUMAN.

(2) IN ANY APPLICATION, INCLUDING THE ABOVE, RELIABILITY OF OPERATION OF THE SOFTWARE PRODUCTS CAN BE IMPAIRED BY ADVERSE FACTORS, INCLUDING BUT NOT LIMITED TO FLUCTUATIONS IN ELECTRICAL POWER SUPPLY, COMPUTER HARDWARE MALFUNCTIONS, COMPUTER OPERATING SYSTEM SOFTWARE FITNESS, FITNESS OF COMPILERS AND DEVELOPMENT SOFTWARE USED TO DEVELOP AN APPLICATION, INSTALLATION ERRORS, SOFTWARE AND HARDWARE COMPATIBILITY PROBLEMS, MALFUNCTIONS OR FAILURES OF ELECTRONIC MONITORING OR CONTROL DEVICES, TRANSIENT FAILURES OF ELECTRONIC SYSTEMS (HARDWARE AND/OR SOFTWARE), UNANTICIPATED USES OR MISUSES, OR ERRORS ON THE PART OF THE USER OR APPLICATIONS DESIGNER (ADVERSE FACTORS SUCH AS THESE ARE HEREAFTER COLLECTIVELY TERMED "SYSTEM FAILURES"). ANY APPLICATION WHERE A SYSTEM FAILURE WOULD CREATE A RISK OF HARM TO PROPERTY OR PERSONS (INCLUDING THE RISK OF BODILY INJURY AND DEATH) SHOULD NOT BE RELIANT SOLELY UPON ONE FORM OF ELECTRONIC SYSTEM DUE TO THE RISK OF SYSTEM FAILURE. TO AVOID DAMAGE, INJURY, OR DEATH, THE USER OR APPLICATION DESIGNER MUST TAKE REASONABLY PRUDENT STEPS TO PROTECT AGAINST SYSTEM FAILURES, INCLUDING BUT NOT LIMITED TO BACK-UP OR SHUT DOWN MECHANISMS. BECAUSE EACH END-USER SYSTEM IS CUSTOMIZED AND DIFFERS FROM NATIONAL INSTRUMENTS' TESTING PLATFORMS AND BECAUSE A USER OR APPLICATION DESIGNER MAY USE NATIONAL INSTRUMENTS PRODUCTS IN COMBINATION WITH OTHER PRODUCTS IN A MANNER NOT EVALUATED OR CONTEMPLATED BY NATIONAL INSTRUMENTS, THE USER OR APPLICATION DESIGNER IS ULTIMATELY RESPONSIBLE FOR VERIFYING AND VALIDATING THE SUITABILITY OF NATIONAL INSTRUMENTS PRODUCTS WHENEVER NATIONAL INSTRUMENTS PRODUCTS ARE INCORPORATED IN A SYSTEM OR APPLICATION, INCLUDING, WITHOUT LIMITATION, THE APPROPRIATE DESIGN, PROCESS AND SAFETY LEVEL OF SUCH SYSTEM OR APPLICATION.

Contents

About This Manual

Conventions	vii
Related Documentation.....	viii

Chapter 1

Getting Started

Unpacking	1-1
What You Need to Get Started	1-1
Key Features	1-2
Chassis Description.....	1-3
Optional Equipment	1-4
EMC Filler Panels	1-4
Rack Mount Kits.....	1-4
Slot Blockers	1-4
PXI-1045 Backplane Overview	1-5
Interoperability with CompactPCI	1-5
System Controller Slot	1-5
Star Trigger Slot	1-6
Peripheral Slots.....	1-6
Local Bus	1-6
Trigger Bus	1-8
System Reference Clock.....	1-8

Chapter 2

Installation and Configuration

Safety Information	2-1
Chassis Cooling Considerations	2-2
Providing Adequate Clearance	2-2
Setting Fan Speed	2-3
Installing Filler Panels	2-3
Installing Slot Blockers	2-3
Rack Mounting	2-4
Connecting Safety Ground.....	2-4
Connecting to Power Source.....	2-4
Installing a PXI Controller.....	2-5
Installing PXI Modules	2-7
Power Switch LED Indicator	2-8
Remote Voltage Monitoring and Control	2-9

10 MHz REF Rear Connectors.....	2-11
10 MHz REF IN.....	2-11
10 MHz REF OUT.....	2-11
PXI System Configuration with MAX.....	2-11
Basic PXI System Configuration.....	2-12
Trigger Configuration in MAX.....	2-13
PXI Trigger Bus Routing.....	2-13
Using System Configuration and Initialization Files.....	2-14

Chapter 3

Maintenance

Service Interval.....	3-1
Preparation.....	3-1
Cleaning.....	3-1
Interior Cleaning.....	3-2
Exterior Cleaning.....	3-2
Cleaning and Replacing the Fan Filters.....	3-2
Resetting the AC Mains Circuit Breaker.....	3-3
Replacing the Modular Power Supply.....	3-3
Removal.....	3-4
Installation.....	3-4
Configuration.....	3-4
Connecting Safety Ground.....	3-5
Connecting to Power Source.....	3-5

Appendix A

Specifications

Appendix B

Pinouts

Appendix C

Technical Support and Professional Services

Glossary

Index

About This Manual

The *NI PXI-1045 User Manual* contains information about installing, configuring, using, and maintaining the NI PXI-1045 18-slot chassis.



Note This manual applies to chassis assemblies 189105E-01 and later. For earlier chassis revisions, refer to ni.com/support.

Conventions

The following conventions are used in this manual:

»

The » symbol leads you through nested menu items and dialog box options to a final action. The sequence **File»Page Setup»Options** directs you to pull down the **File** menu, select the **Page Setup** item, and select **Options** from the last dialog box.



This icon denotes a note, which alerts you to important information.



This icon denotes a caution, which advises you of precautions to take to avoid injury, data loss, or a system crash. When this symbol is marked on a product, refer to the *Read Me First: Safety and Radio-Frequency Interference* document for information about precautions to take.

bold

Bold text denotes items that you must select or click in the software, such as menu items and dialog box options. Bold text also denotes parameter names.

italic

Italic text denotes variables, emphasis, a cross reference, or an introduction to a key concept. Italic text also denotes text that is a placeholder for a word or value that you must supply.

monospace

Text in this font denotes text or characters that you should enter from the keyboard, sections of code, programming examples, and syntax examples. This font is also used for the proper names of disk drives, paths, directories, programs, subprograms, subroutines, device names, functions, operations, variables, filenames, and extensions.

Related Documentation

The following documents contain information that you might find helpful as you read this manual:

- *CompactPCI Specification PICMG 2.0 R 3.0*
- *PXI Hardware Specification, Revision 2.2*
- *PXI Software Specification, Revision 2.2*
- *IEEE 1101.1-1991, IEEE Standard for Mechanical Core Specifications for Microcomputers Using IEC 603-2 Connectors*
- *IEEE 1101.10, IEEE Standard for Additional Mechanical Specifications for Microcomputers Using IEEE 1101.1 Equipment Practice*

Getting Started

This chapter describes the key features of the PXI-1045 chassis and lists the kit contents and optional equipment you can order from National Instruments.

Unpacking

Carefully inspect the shipping container and the chassis for damage. Check for visible damage to the metal work. Check to make sure all handles, hardware, and switches are undamaged. Inspect the inner chassis for any possible damage, debris, or detached components. If damage appears to have been caused during shipment, file a claim with the carrier. Retain the packing material for possible inspection and/or reshipment.

What You Need to Get Started

The PXI-1045 kit contains the following items:

- PXI-1045 chassis
- Filler panels
- AC power cable (refer to Table 1-1 for AC power cables)
- NI PXI-1045 User Manual*
- Read Me First: Safety and Radio-Frequency Interference*
- Driver CD-ROM containing NI PXI chassis software
- Chassis number labels

Table 1-1. AC Power Cables

Power Cable	Reference Standards
Standard 120 V (USA)	ANSI C73.11/NEMA 5-15-P/IEC83
Switzerland 220 V	SEV
Australia 240 V	AS C112
Universal Euro 230 V	CEE (7), II, IV, VII IEC83
North America 120 V	ANSI C73.20/NEMA 5-15-P/IEC83
United Kingdom 230 V	BS 1363/IEC83

If you are missing any of the above items, or if you have the incorrect AC power cable, contact National Instruments.

Key Features

The PXI-1045 combines a high-performance 18-slot PXI backplane with a high-output power supply and a structural design that has been optimized for maximum usability in a wide range of applications. The chassis' modular design ensures a high level of maintainability, resulting in a very low mean time to repair (MTTR). The PXI-1045 complies with the *PXI Hardware Specification, Revision 2.1*, offering advanced timing and synchronization features.

The key features of the PXI-1045 include the following:

- PXI and CompactPCI (PICMG 2.0 R 3.0) module compatibility
- 3U-sized, 18-slot chassis
- Universal AC input: automatic voltage and frequency ranging
- Over-current protection through push-reset circuit breaker (no AC-input fuses to replace)
- Removable modular power-supply shuttle
- Remote voltage monitoring and inhibit through a rear-panel connector
- On/Off (Standby) power switch on the front panel for easy access
- Temperature-sensing module that can adjust fan speed based on air-intake temperature to minimize audible noise

- Front-panel LED that can indicate power supply failure
- 10 MHz REF IN and OUT BNC connectors for synchronizing multiple chassis using PXI_CLK10
- Programmable PXI trigger routing between PXI bus segments
- Carrying handle for portability
- Tilt feet for bench-top applications
- Rack mountable

Chassis Description

Figures 1-1 and 1-2 show the key features of the PXI-1045 chassis front and rear panels. Figure 1-1 shows the front view of the PXI-1045. Figure 1-2 shows the rear view.

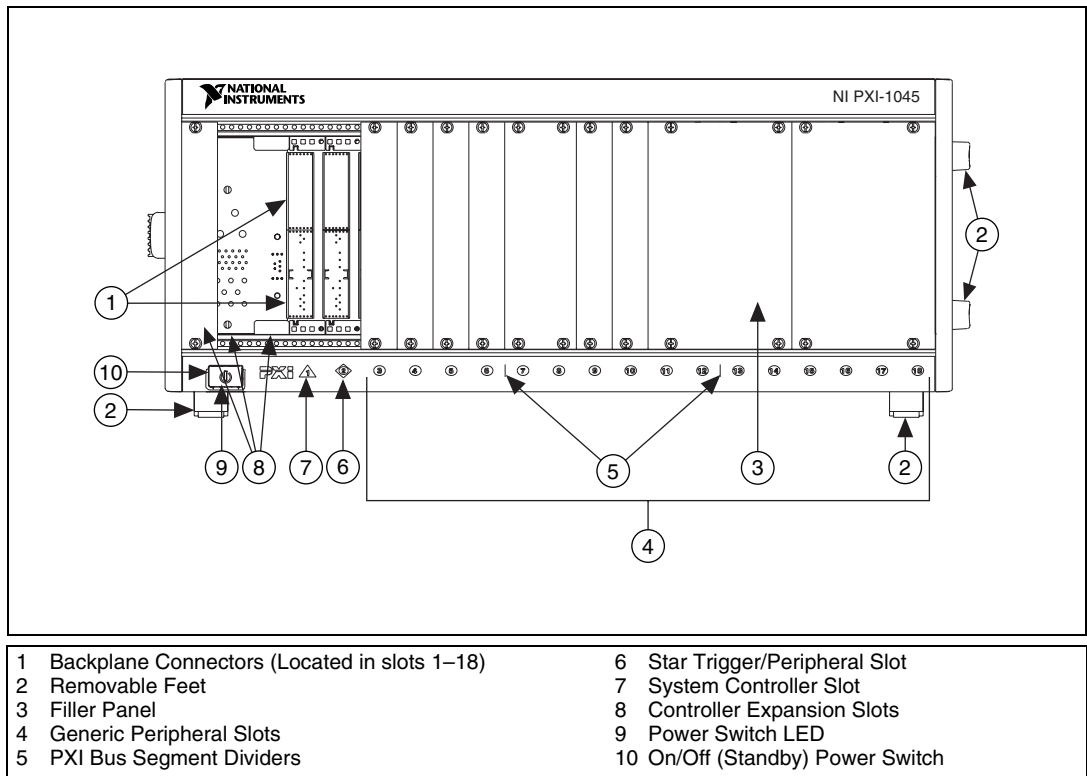

Figure 1-1. Front View of the PXI-1045 Chassis

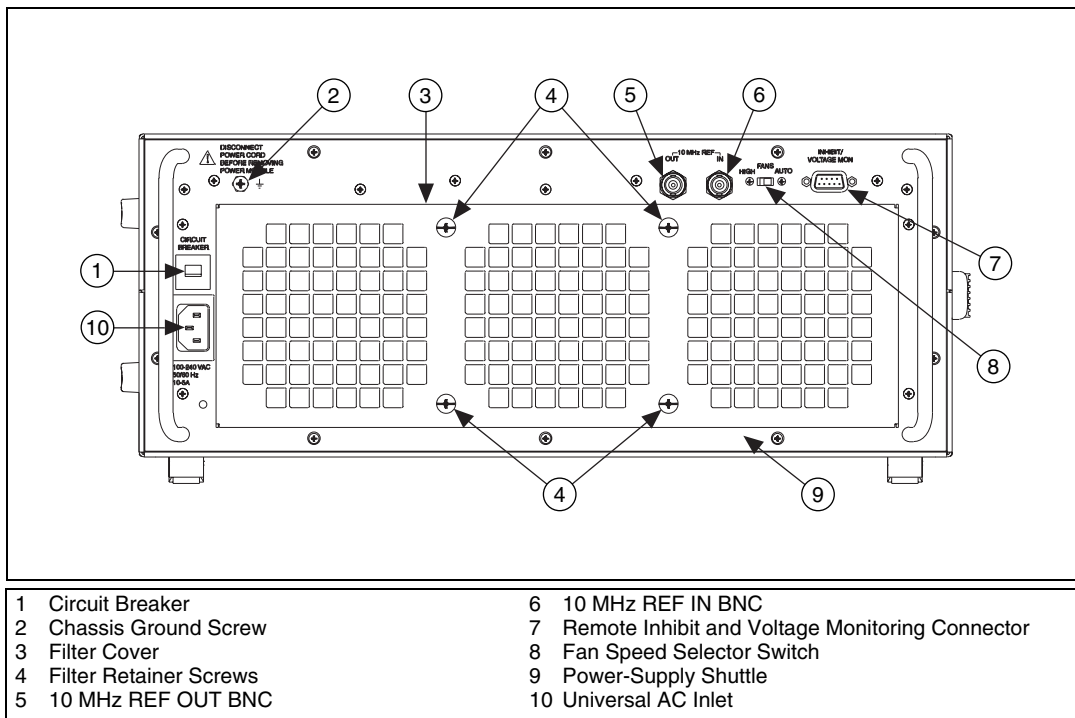

Figure 1-2. Rear View of the PXI-1045 Chassis

Optional Equipment

Contact National Instruments to order the following options for the PXI-1045 chassis.

EMC Filler Panels

Optional EMC filler panel kits are available from National Instruments.

Rack Mount Kits

Two rack mount kit options are available for mounting the PXI-1045 chassis into a 19 in. instrument cabinet.

Slot Blockers

Optional slot blocker kits are available from National Instruments for improved thermal performance when all slots are not used.

PXI-1045 Backplane Overview

Interoperability with CompactPCI

The PXI-1045 backplane is interoperable with 5 V and universal PXI-compatible products and standard CompactPCI products. This is an important feature, because some PXI systems may require components that do not implement PXI-specific features. For example, you may want to use a standard CompactPCI network interface card in a PXI chassis.

The signals on the backplane P1 connectors meet the requirements of the CompactPCI specification for both peripheral and system modules. Refer to Appendix B, *Pinouts*, for pinout information.

The PXI-specific signals are on the backplane P2 connectors and are found only on those signal lines reserved or not used in the CompactPCI 64-bit specification. Therefore, all modules that meet the requirements of the CompactPCI 64-bit specification will function in the PXI-1045. Refer to Appendix B, *Pinouts*, for pinout information.

The PXI-1045 has three PXI bus segments linked through two 32-bit/33 MHz PXI bridges. The PXI bus segment divisions are represented on the front of the chassis by vertical lines as shown in Figure 1-1.



Note The PXI-1045 backplane is 32-bit PCI; 64-bit CompactPCI cards will operate in 32-bit mode in this chassis.

The PXI-1045 backplane has +5 V V(I/O). Refer to the *CompactPCI Specification PICMG 2.0 R3.0* for details regarding V(I/O).

System Controller Slot

The system controller slot is slot 1 of the chassis as defined by the PXI Specification. It has three controller expansion slots for system controller modules that are wider than one slot. As defined in the PXI specification, these slots allow the controller to expand to the left to prevent the controller from using peripheral slots.

Star Trigger Slot

The star trigger (ST) slot is slot 2. This slot has dedicated equal-length trigger lines between slot 2 and peripheral slots 3 through 15 (refer to Figure 1-3). The PXI Specification defines only 13 star trigger lines; therefore, the last three slots do not receive a star trigger. Slot 2 is intended for modules with ST functionality that can provide individual triggers to all other peripheral modules. However, if you do not require advanced trigger functionality, you can install any standard peripheral module in this slot.

The star trigger slot can also be used to provide a PXI_CLK10 signal to the backplane. For more information regarding PXI_CLK10, refer to the [System Reference Clock](#) section.

Peripheral Slots

There are 17 peripheral slots including the star trigger slot.

Local Bus

The PXI backplane local bus is a daisy-chained bus that connects each peripheral slot with adjacent peripheral slots to the left and right (refer to Figure 1-3). For example, slot 2's right local bus connects to slot 3's left local bus, and so on.

The left local bus signal lines on slot 2 are used for star trigger and do not connect to slot 1. The right local bus signal lines on slot 18 are not routed anywhere.

Each local bus is 13 lines wide and can pass analog signals up to 42 V between cards or provide a high-speed TTL side-band digital communication path that does not reduce the PXI bus bandwidth.

Initialization software uses the configuration information specific to adjacent peripheral modules to evaluate local bus compatibility.

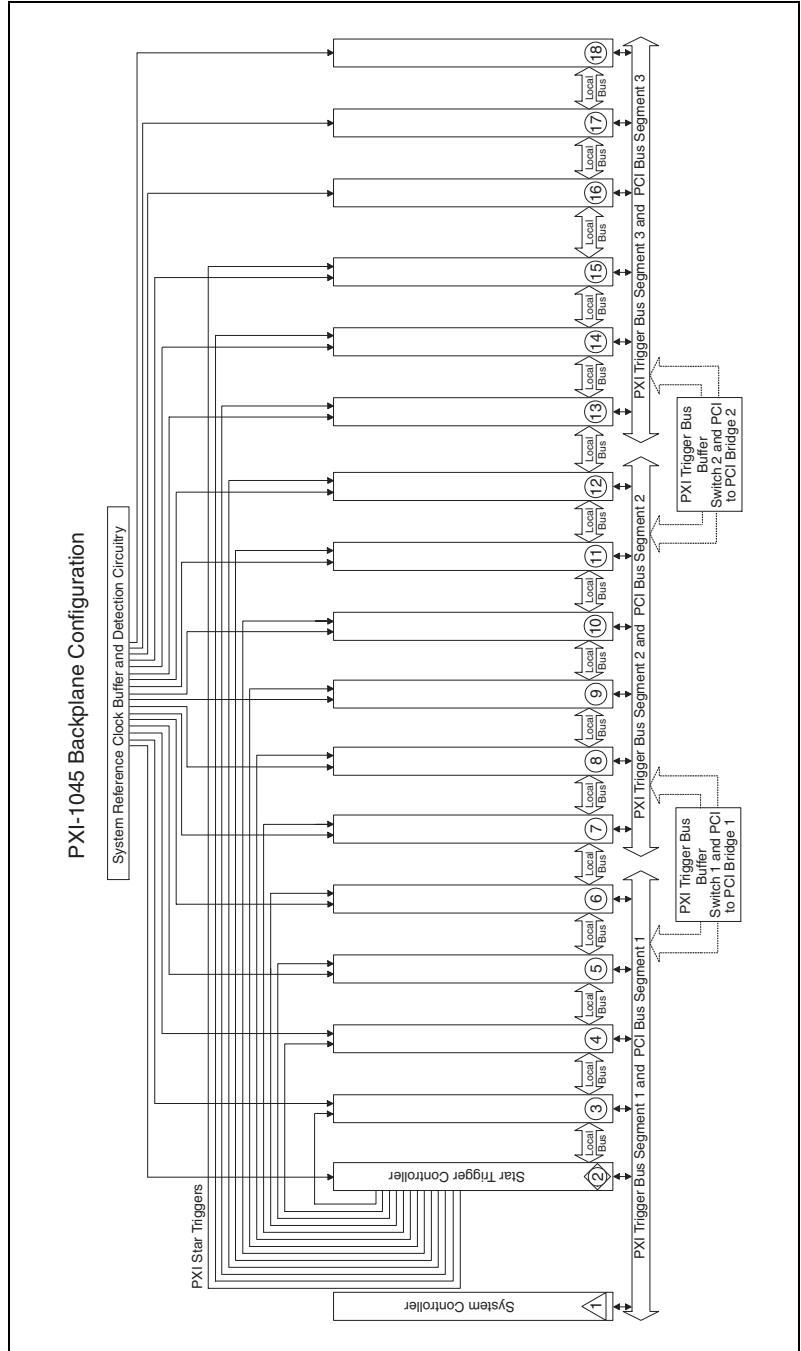

Figure 1-3. PXI CLK_10 and Star Trigger Routing

Trigger Bus

All slots on each PXI bus segment share eight PXI trigger lines. You can use these trigger lines in a variety of ways. For example, you can use triggers to synchronize the operation of several different PXI peripheral modules. In other applications, one module located in slot 2 can control carefully timed sequences of operations performed on other modules in the system. Modules can pass triggers to one another, allowing precisely timed responses to asynchronous external events the system is monitoring or controlling.

The PXI trigger lines from adjacent PXI trigger bus segments can be routed in either direction across the PXI bridges through buffers. This allows you to send trigger signals to, and receive trigger signals from, every slot in the chassis. Static trigger routing (user-specified line and directional assignments) can be configured through Measurement & Automation Explorer (MAX). Dynamic routing of triggers (automatic line assignments) is supported through certain National Instruments drivers like NI-DAQmx.



Note Although any trigger line may be routed in either direction, it cannot be routed in more than one direction at a time.

System Reference Clock

The PXI-1045 supplies the PXI 10 MHz system clock signal (PXI_CLK10) independently to each peripheral slot. An independent buffer (having a source impedance matched to the backplane and a skew of less than 250 ps between slots) drives the clock signal to each peripheral slot. You can use this common reference clock signal to synchronize multiple modules in a measurement or control system. You can drive PXI_CLK10 from an external source through the PXI_CLK10_IN pin on the P2 connector of the star trigger slot. Refer to Table B-4, *P2 (J2) Connector Pinout for the Star Trigger Slot*. Sourcing an external clock on this pin automatically overrides the backplane's 10 MHz source. You also can drive PXI_CLK10 from the 10 MHz REF IN BNC connector on the rear of the chassis (refer to Figure 1-2). Sourcing an external clock on this connector automatically overrides the backplane's 10 MHz clock. If the clock signal is present on both the PXI_CLK10_IN pin of the star trigger slot and the 10 MHz REF IN connector on the rear of the chassis, the signal on the star trigger slot is selected and provided to all peripheral slots and the external 10 MHz REF OUT connector on the rear of the chassis.

Installation and Configuration

This chapter describes how to install, configure, and use the PXI-1045 chassis.

Before connecting the chassis to a power source, read this chapter and the *Read Me First: Safety and Radio-Frequency Interference* document included with your chassis.

Safety Information



Caution Before undertaking any troubleshooting, maintenance, or exploratory procedure, carefully read the following caution notices.

This equipment contains voltage hazardous to human life and safety, and is capable of inflicting personal injury.

- **Chassis Grounding**—The PXI-1045 requires a connection from the premise wire safety ground to the PXI-1045 chassis ground. The earth safety ground *must* be connected during use of this equipment to minimize shock hazards. Refer to the [Connecting Safety Ground](#) section for instructions on connecting safety ground.
- **Live Circuits**—Operating personnel and service personnel *must* not remove protective covers when operating or servicing the PXI-1045. Adjustments and service to internal components must be undertaken by qualified service technicians. During service of this product, the mains connector to the premise wiring must be disconnected. Dangerous voltages may be present under certain conditions; use extreme caution.
- **Explosive Atmosphere**—Do *not* operate the chassis in conditions where flammable gases are present. Under such conditions this equipment is unsafe and may ignite the gases or gas fumes.
- **Part Replacement**—Only service this equipment with parts that are exact replacements, both electrically and mechanically. Contact National Instruments for replacement part information. Installation of

parts with those that are not direct replacements may cause harm to personnel operating the chassis. Furthermore, damage or fire may occur if replacement parts are unsuitable.

- **Modification**—Do *not* modify any part of the chassis from its original condition. Unsuitable modifications may result in safety hazards.

Chassis Cooling Considerations

The PXI-1045 is designed to operate on a bench or in an instrument rack. Determine how you want to use the PXI-1045 and follow the appropriate installation instructions.

Providing Adequate Clearance

Apertures in the top and along both sides of the chassis facilitate power supply and module cooling. Air enters through filters and fan inlets in the lower rear of the chassis and exits through the upper sections on both sides and through the top, as shown in Figure 2-1. Place the PXI-1045 on a bench top or in an instrument rack so that the fans (air inlets) and the air outlet apertures along both sides and the top of the chassis have adequate ventilation. Keep other equipment a minimum of 76.2 mm (3 in.) away from the air inlets on the rear of the chassis.

When rack mounting the PXI-1045, provide at least 44.5 mm (1.75 in.) clearance above and on the sides of the unit for adequate venting. High-power applications may require additional clearance.

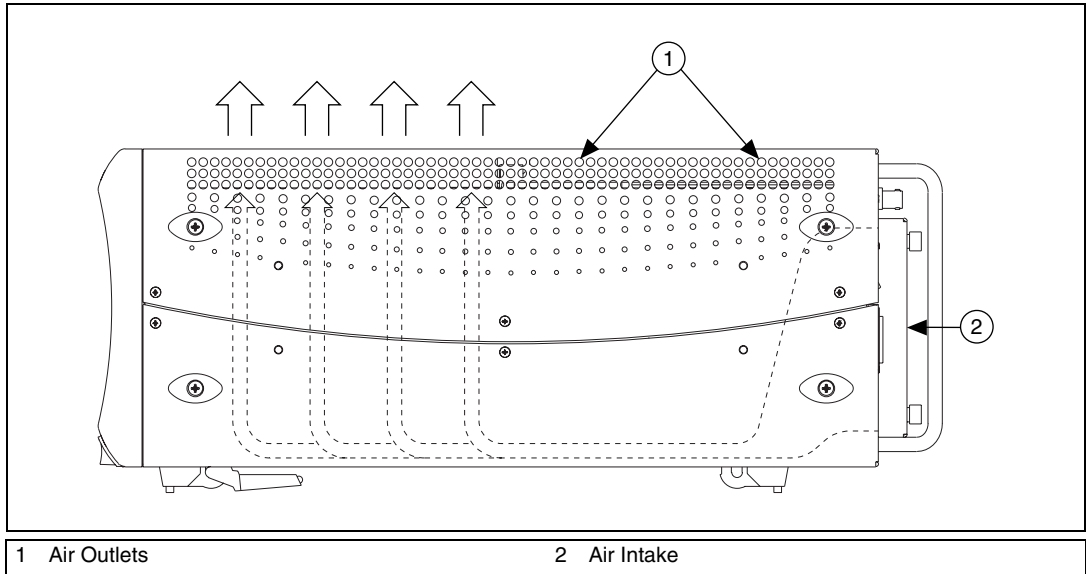

Figure 2-1. PXI-1045 Chassis Airflow Side View

Install the chassis so that you can easily access the rear panel. This simplifies replacing the air filters or power supply shuttle, if necessary.

Setting Fan Speed

The fan-speed selector switch is on the rear panel of the PXI-1045. Refer to Figure 1-2, *Rear View of the PXI-1045 Chassis*, to locate the fan-speed selector switch. Select HIGH for maximum cooling performance (recommended) or AUTO for quieter operation. When set to AUTO, the fan speed is determined by chassis intake air temperature.

Installing Filler Panels

To improve module cooling performance, install filler panels (provided with the chassis) in unused or empty slots. Secure with the captive mounting screws provided.

Installing Slot Blockers

The cooling performance of the chassis can be improved by installing optional slot blockers. Visit ni.com/support to read the National Instruments KnowledgeBase article 2S4928ON, *PXI Slot Blockers and Improved PXI System Cooling Performance*, for more details.

Rack Mounting

Rack-mount applications require the optional rack-mount kits available from National Instruments. Refer to Figure A-3, [PXI-1045 Rack Mount Kit Components](#), and the instructions supplied with the rack-mount kits to install your PXI-1045 in an instrument rack.



Note You may want to remove the feet from the PXI-1045 when rack mounting. To do so, remove the screws holding the feet in place.

Connecting Safety Ground



Caution The PXI-1045 chassis is designed with a three-position NEMA 5-15 style plug for the U.S. that connects the ground line to the chassis ground. To minimize shock hazard, make sure the electrical power outlet you use to power the chassis has an appropriate earth safety ground.

If your power outlet does not have an appropriate ground connection, you must connect the premise safety ground to the chassis grounding screw located on the rear panel. Refer to Figure 1-2, [Rear View of the PXI-1045 Chassis](#), to locate the chassis grounding screw. Complete the following steps to connect the safety ground.

1. Connect a 16 AWG (1.3 mm) wire to the chassis grounding screw using a grounding lug. The wire must have green insulation with a yellow stripe or must be noninsulated (bare).
2. Attach the opposite end of the wire to permanent earth ground using toothed washers or a toothed lug.

Connecting to Power Source



Caution Do *not* install modules prior to performing the following power-on test.

Attach input power through the rear AC inlet using the appropriate AC power cable supplied. Refer to Figure 1-2, [Rear View of the PXI-1045 Chassis](#), to locate the AC inlet.



Caution To completely remove power, you *must* disconnect the AC power cable.

The power switch allows you to power on the chassis or place it in standby mode. Push the power switch to the On (recessed) position (if not already on). Observe that all fans become operational and the power switch LED is a steady green.

Installing a PXI Controller

This section contains general instructions for installing a PXI controller in the PXI-1045 chassis. Refer to your PXI controller user manual for specific instructions and cautions. Complete the following steps to install a controller.

1. Plug in the PXI chassis before installing the controller. The power cord grounds the chassis and protects it from electrical damage while you install the controller. Make sure the chassis power switch is in the Off (Standby) position.



Caution To protect both yourself and the chassis from electrical hazards, leave the chassis off until you finish installing the controller.

2. Install the controller into the system controller slot (slot 1, indicated by the red card guides) by first placing the controller edges into the front controller guides (top and bottom). Slide the controller to the rear of the chassis (making sure that the injector/ejector handle is pushed down as shown in Figure 2-2).

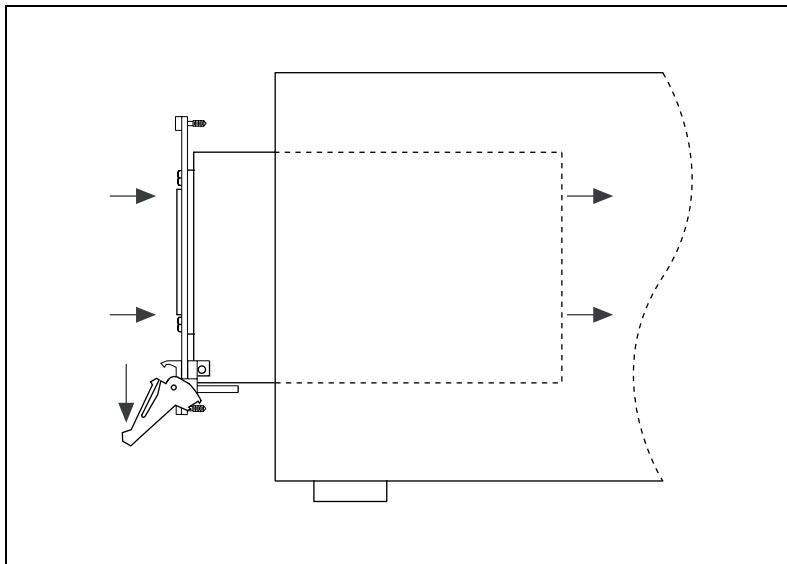

Figure 2-2. Injector/Ejector Handle Position during Controller or Peripheral Module Insertion

3. When you begin to feel resistance, push up on the injector/ejector handle to inject the controller fully into the chassis frame. Secure the controller front panel to the chassis using the controller front-panel mounting screws.
4. Connect the keyboard, mouse, and monitor to the appropriate connectors. Connect devices to ports as required by your system configuration.
5. Power on the chassis. Verify that the controller boots. If the controller does not boot, refer to your controller user manual.

Figure 2-3 shows a PXI controller installed in the system controller slot of a PXI-1045 chassis. You can place CompactPCI or PXI modules in any other slot.

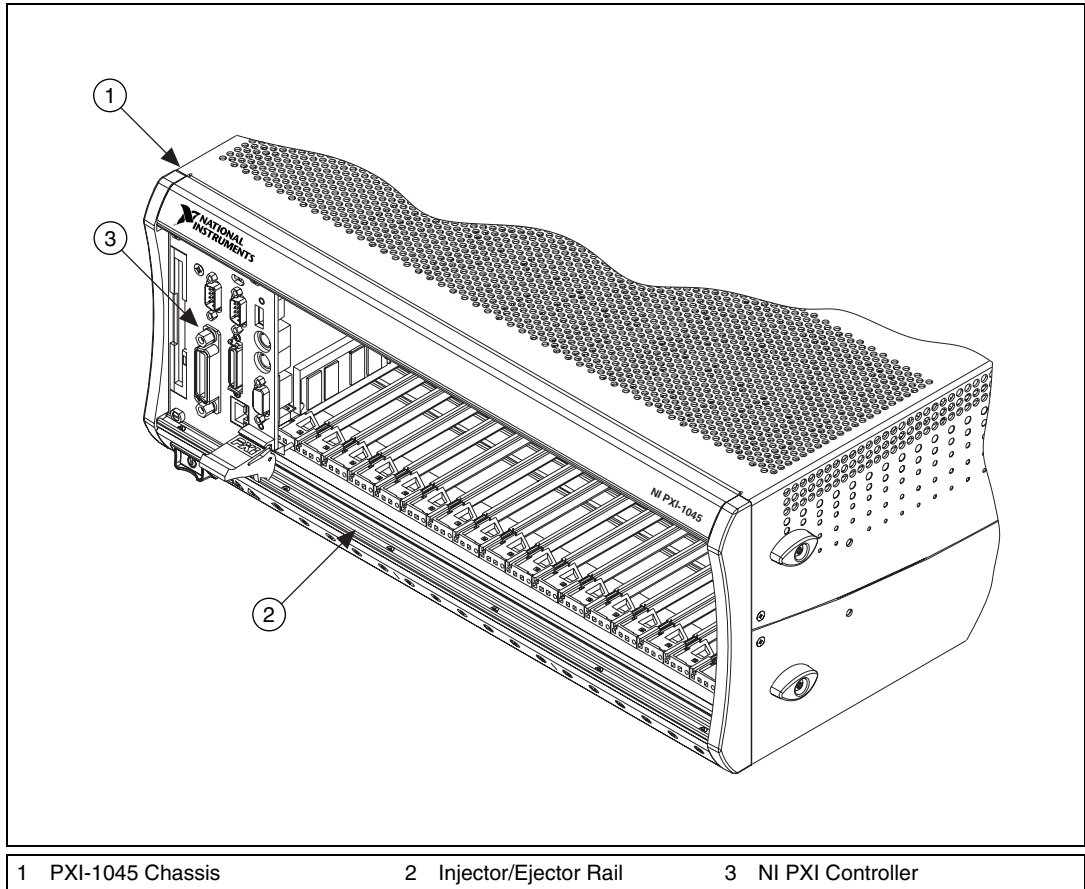

Figure 2-3. NI PXI Controller Installed in a PXI-1045 Chassis

Installing PXI Modules

Complete the following steps to install a module.

1. Make sure the power switch is in the Off (Standby) position.
2. Install a module into a chassis slot by first placing the module card edges into the front module guides (top and bottom), as shown in Figure 2-4. Slide the module to the rear of the chassis, making sure that the injector/ejector handle is pushed down as shown in Figure 2-2.
3. When you begin to feel resistance, push up on the injector/ejector handle to fully inject the module into the chassis frame. Secure the module front panel to the chassis using the module front-panel mounting screws.

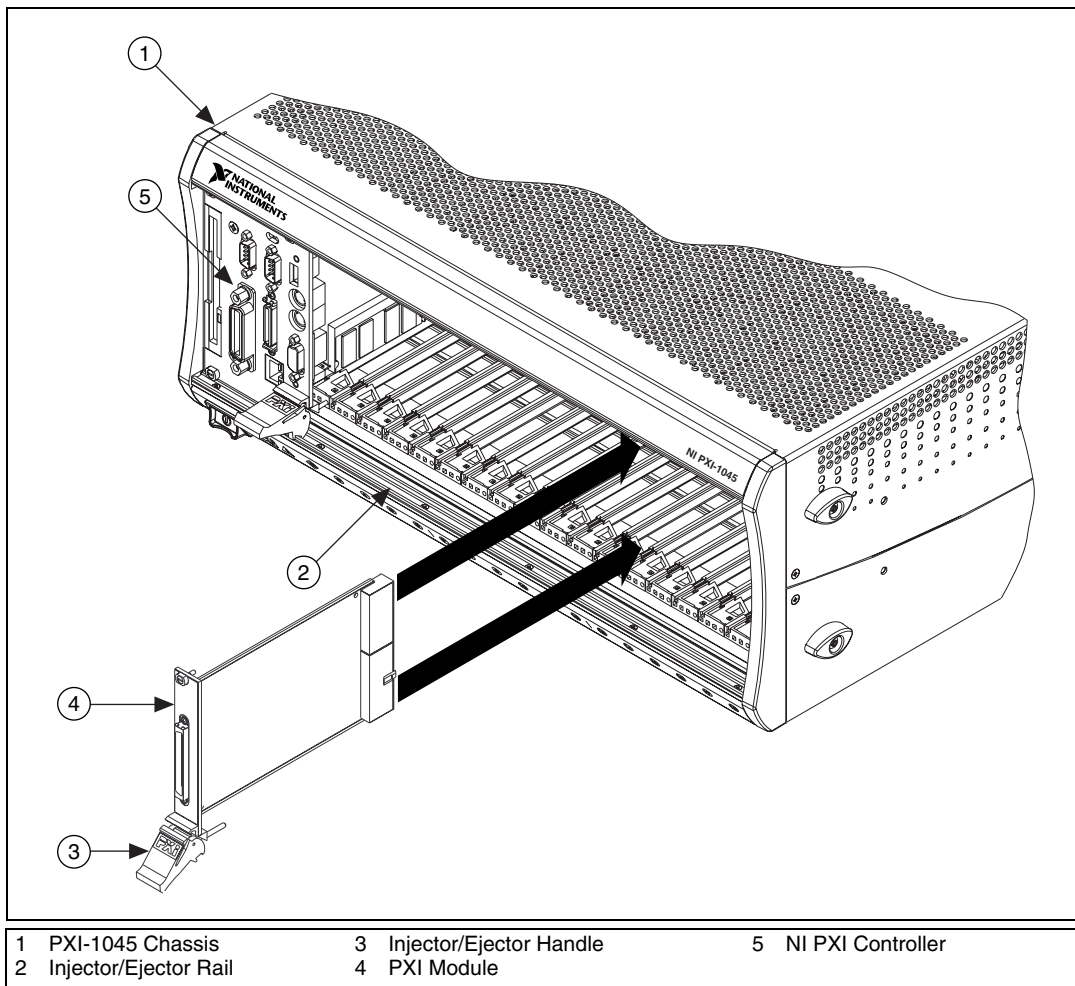

Figure 2-4. Installing PXI or CompactPCI Modules

Power Switch LED Indicator

The chassis power switch has an integrated LED. This LED indicates one of three different conditions:

- If the power switch LED is steady green (not flashing), the chassis is powered on and operating normally.



Caution Operating the PXI system outside of the specified temperature range may result in loss of data, reduction of chassis life, or damage to equipment.

- If the power switch LED is flashing green, the air-intake temperature has exceeded the chassis operating range.



Caution Power supply output voltages out of regulation may result in equipment malfunction, incorrect data, or failure of system to boot.

- If the power switch LED is flashing red, the power supply outputs are not within voltage regulation requirements.

Remote Voltage Monitoring and Control

The PXI-1045 chassis supports remote voltage monitoring and inhibiting through a male 9-pin D-sub connector located on the rear panel. Table 2-1 shows the pinout of the 9-pin D-sub connector.

Table 2-1. Remote Inhibit and Voltage Monitoring Connector Pinout

D-sub Pin	Signal
1	Logic Ground
2	+5 VDC
3	Reserved
4	+3.3 VDC
5	Inhibit (Active Low)
6	+12 VDC
7	Reserved
8	-12 VDC
9	Logic Ground

You can use the Inhibit signal (active low) to power off the chassis. To remotely power off the chassis, connect the Inhibit pin (pin 5) to a Logic Ground pin (pin 1 or 9). As long as this connection exists, the chassis will remain off (standby); when you remove this connection, the chassis turns on.



Note For the Inhibit signal to control the On/Off (Standby) state of the chassis, the front power switch must be in the On (recessed) position.



Caution When connecting digital voltmeter probes to the rear 9-pin D-sub connector, be careful not to short the probe leads together. Doing so could damage the power supply.



Caution Use the rear-panel 9-pin D-sub connector to check voltages only. Do *not* use the connector to supply power to external devices, or damage to the chassis may result.

You can use a digital voltmeter to ensure all voltage levels in the PXI-1045 are within the allowable limits. Referring to Table 2-2, connect one lead of the voltmeter to a supply pin on the remote power monitoring connector (9-pin D-sub) on the rear panel. Refer to Table 2-1 for a pinout diagram of the remote voltage monitoring connector. Connect the reference lead of the voltmeter to one of the ground pins. Compare each voltage reading to the values listed in Table 2-2.

Table 2-2. Power Supply Voltages at Voltage Monitoring Connector

Pin	Supply	Acceptable Voltage Range
2	+5 V	4.75 to 5.25 V
4	+3.3 V	3.135 to 3.465 V
6	+12 V	11.4 to 12.6 V
8	-12 V	-12.6 to -11.4 V
1, 9	Logic Ground	0 V

If the voltages fall within the specified ranges, the chassis complies with the CompactPCI voltage-limit specifications.

10 MHz REF Rear Connectors

There are two BNC connectors on the rear of the PXI-1045 chassis designated 10 MHz REF. The connectors are labeled IN and OUT. You can use them for supplying the backplane with a 10 MHz reference clock or routing the backplane's PXI_CLK10 signal to another chassis.

10 MHz REF IN

You can use the 10 MHz REF IN connector to supply an external 10 MHz clock to the backplane PXI_CLK10. This external clock signal will be buffered and provided to each peripheral slot's PXI_CLK10 pin with a maximum slot-to-slot skew of 250 ps. When the backplane detects a 10 MHz signal on the 10 MHz REF IN connector, it automatically overrides the 10 MHz clock provided by the backplane and uses the externally provided clock. If the backplane detects a 10 MHz clock on the PXI_CLK10_IN pin of slot 2 and a 10 MHz clock on the 10 MHz REF IN connector, the backplane automatically selects the signal from slot 2 and provides that signal to each peripheral slot.

The input impedance of the 10 MHz REF IN connector on the rear of the chassis is $50 \Omega \pm 5 \Omega$. The backplane accepts a 10 MHz clock signal between 200 mV_{pp} and 5 V_{pp} and rejects any DC component of the 10 MHz REF IN signal. The input signal may be a 10 MHz square wave or sine wave.

10 MHz REF OUT

The 10 MHz REF OUT connector provides a buffered non-TTL version of the PXI_CLK10 TTL signal supplied to the peripheral slots on the backplane. You can use this signal to synchronize multiple PXI chassis to the same PXI_CLK10 signal.

The output impedance of this connector is $50 \Omega \pm 5 \Omega$. The output signal is a $1 \text{ V}_{pp} \pm 20\%$ non-TTL square wave.

PXI System Configuration with MAX

Configuration of the PXI system is handled through Measurement & Automation Explorer (MAX), included on the NI Driver CD-ROM packaged with your kit. MAX creates the `pxisys.ini` file which defines the layout and parameters of your PXI system. After installing the software on the NI Driver CD-ROM, the MAX icon will be present on the desktop.

The configuration steps for single- or multiple-chassis systems are the same.

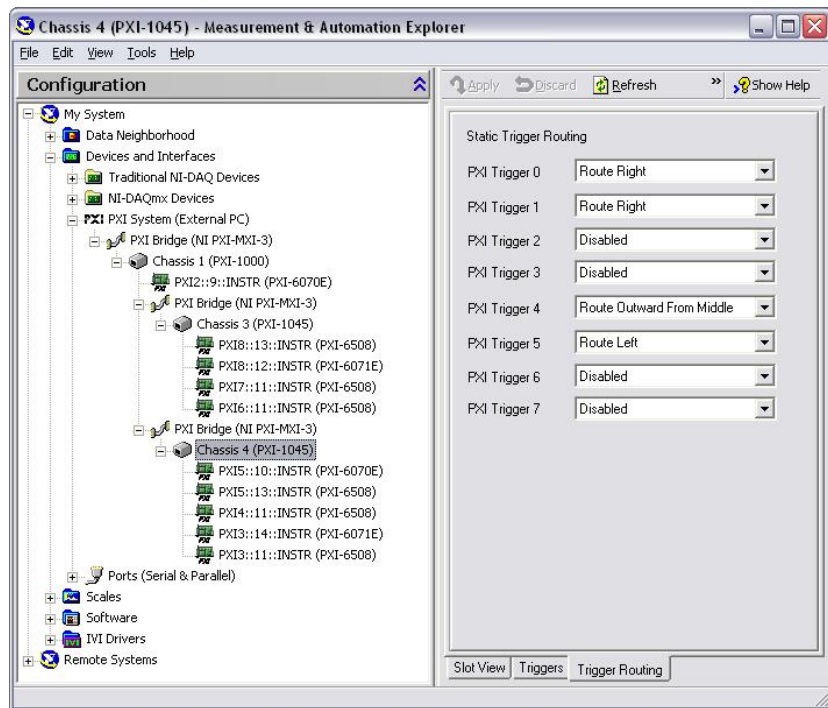

Figure 2-5. Multichassis Configuration in MAX

Basic PXI System Configuration

1. Launch MAX.
2. In the **Configuration** tree, click on the **Devices and Interfaces** branch to expand it.
3. If the PXI system controller has not yet been configured, it will be labeled “PXI System (Unidentified).” Right-click on this entry to display the popup menu, then select the appropriate controller model from the **Identify As** submenu.
4. Click on the **PXI System** controller and the chassis (or multiple chassis, in a multi-chassis configuration) will be listed below it. Identify each chassis by right-clicking on its entry, then selecting the appropriate chassis model through the **Identify As** submenu. Further expanding the **PXI System** branch will show all of the devices in the system that can be recognized by NI-VISA. Once your controller and

all of your chassis have been identified, the required `pxisys.ini` file will be complete.

5. Apply the chassis number labels (shown in Figure 2-6) included with your kit to each chassis in your PXI system, and write in the chassis number accordingly in the white space.



Figure 2-6. Chassis Number Label

Trigger Configuration in MAX

Each chassis has one or more trigger buses, each with eight lines numbered 0 through 7 that can be reserved and routed statically or dynamically. Static reservation “pre-allocates” a trigger line to prevent its configuration by a user program. Dynamic reservation/routing/deallocation is “on the fly” within a user program based upon National Instruments APIs such as NI-DAQmx. Static reservation of trigger lines can be implemented by the user in MAX through the **Triggers** tab. Reserved trigger lines will not be used by PXI modules dynamically configured by programs such as NI-DAQmx. This prevents the instruments from double-driving the trigger lines, possibly damaging devices in the chassis. In the default configuration, trigger lines on each bus are independent. For example, if trigger line 3 is asserted on trigger bus 0, by default it will not be automatically asserted on any other trigger bus.

Complete the following steps to reserve these trigger lines in MAX.

1. In the **Configuration** tree, click on the PXI chassis branch you want to configure.
2. Then, in the right-hand pane, toward the bottom, click on the **Triggers** tab.
3. Select which trigger lines you would like to statically reserve.
4. Click the **Apply** button.

PXI Trigger Bus Routing

Some National Instruments chassis, such as the PXI-1006 and the PXI-1045, have the capability to route triggers from one bus to others within the same chassis using the **Trigger Routing** tab in MAX, as shown in Figure 2-5. This tab allows the routing of triggers from any single trigger bus to all of the other trigger buses in the chassis.



Note Selecting any non-disabled routing automatically reserves the line in all trigger buses being routed to. If you are using NI-DAQmx, it will reserve and route trigger lines for you, so you won't have to route trigger lines manually.

Complete the following steps to configure trigger routings in MAX.

1. In the **Configuration** tree, select the chassis in which you want to route trigger lines.
2. In the right-hand pane, select the **Trigger Routing** tab near the bottom.
3. For each trigger line, select **Route Right**, **Route Outward From Middle**, or **Route Left** to route triggers on that line in the described direction, or select **Disabled** for the default behavior with no manual routing.
4. Click the **Apply** button.

Using System Configuration and Initialization Files

The PXI specification allows many combinations of PXI chassis and system modules. To assist system integrators, the manufacturers of PXI chassis and system modules must document the capabilities of their products. The minimum documentation requirements are contained in `.ini` files, which consist of ASCII text. System integrators, configuration utilities, and device drivers can use these `.ini` files.

The capability documentation for the PXI-1045 chassis is contained in the `chassis.ini` file on the software media that comes with the chassis. The information in this file is combined with information about the system controller to create a single system initialization file called `pxisys.ini` (PXI System Initialization). The system controller manufacturer either provides a `pxisys.ini` file for the particular chassis model that contains the system controller or provides a utility that can read an arbitrary `chassis.ini` file and generate the corresponding `pxisys.ini` file. System controllers from National Instruments use the Measurement & Automation Explorer (MAX) to generate the `pxisys.ini` file from the `chassis.ini` file.

Device drivers and other utility software read the `pxisys.ini` file to obtain system information. Device drivers should have no need to directly read the `chassis.ini` file. For detailed information regarding initialization files, refer to the PXI specification at www.pxisa.org.

Maintenance

This chapter describes basic maintenance procedures you can perform on the PXI-1045 chassis.



Caution Disconnect the power cable prior to servicing the PXI-1045 chassis.

Service Interval

Clean the chassis fan filters at a maximum interval of six months. Depending on the amount of use and ambient dust levels in the operating environment, the filters may require more frequent cleaning.

Clean dust from the chassis exterior (and interior) as needed, based on the operating environment. Periodic cleaning increases reliability.

Preparation

The information in this chapter is designed for use by qualified service personnel. Read the *Read Me First: Safety and Radio-Frequency Interference* document included with your kit before attempting any procedures in this chapter.



Caution Many components within the chassis are susceptible to static discharge damage. Service the chassis only in a static-free environment. Observe standard handling precautions for static-sensitive devices while servicing the chassis. Always wear a grounded wrist strap, or equivalent, while servicing the chassis.

Cleaning



Caution Always disconnect the AC power cable before cleaning or servicing the chassis.

Cleaning procedures consist of exterior and interior cleaning of the chassis and cleaning the fan filters. Refer to your module user documentation for information on cleaning individual CompactPCI or PXI modules.

Interior Cleaning

Use a dry, low-velocity stream of air to clean the interior of the chassis. Use a soft-bristle brush for cleaning around components. If you must use a liquid for minor interior cleaning, use a 75% isopropyl alcohol solution and rinse with deionized water.

Exterior Cleaning



Cautions Avoid getting moisture inside the chassis during exterior cleaning, especially through the top vents. Use just enough moisture to dampen the cloth.

Do *not* wash the front- or rear-panel connectors or switches. Cover these components while cleaning the chassis.

Do *not* use harsh chemical cleaning agents; they may damage the chassis. Avoid chemicals that contain benzene, toluene, xylene, acetone, or similar solvents.

Clean the exterior surfaces of the chassis with a dry lint-free cloth or a soft-bristle brush. If any dirt remains, wipe with a cloth moistened in a mild soap solution. Remove any soap residue by wiping with a cloth moistened with clear water. Do *not* use abrasive compounds on any part of the chassis.

Cleaning and Replacing the Fan Filters

Dirty fan filters can dramatically reduce the cooling performance of the PXI-1045 chassis. Clean the filters whenever they become visibly dirty. You can easily remove the chassis air filters from the rear of the chassis by removing the filter retainer. To remove the filter retainer, loosen the retainer screws. The filter cover and retainer are shown in Figure 1-2, [Rear View of the PXI-1045 Chassis](#).

Clean the fan filters by washing them in a mild soap solution and then vacuuming or blowing air through them. Rinse the filters with water and allow them to dry before reinstalling them on the chassis.

If desired, you can replace the fan filters with part number FF 450-A/30P from Air Filtration Products, Inc., Tucson, AZ 85705.

The same filter media can be purchased in sheets, and a rectangular section of this material can be used instead of three separate filters.

Resetting the AC Mains Circuit Breaker

If the PXI-1045 is connected to an AC source and encounters an over-current condition, the circuit breaker on the rear panel will trip to prevent damage to the chassis. Complete the following steps to reset the circuit breaker.

1. Set the front-panel power switch to the Off (nonrecessed) position.
2. Disconnect the AC power cable.
3. Depress the circuit breaker to reset it.
4. Reconnect the AC power cable.
5. Set the power switch to the On (recessed) position.

If the circuit breaker trips again, complete the following steps.

1. Press the front-panel power switch to the Off (nonrecessed) position.
2. Disconnect the AC power cable.
3. Remove all modules from the chassis.
4. Complete the procedure described in the [Connecting to Power Source](#) section of Chapter 2, [Installation and Configuration](#). If the power switch LED is not a steady green, contact National Instruments.
5. Verify that the PXI-1045 can meet the power requirements of your CompactPCI or PXI modules. Overloading the chassis can cause the breaker to trip. Refer to Appendix A, [Specifications](#).
6. The over-current condition that caused the circuit breaker to trip may be due to a faulty CompactPCI or PXI module. Refer to the documentation supplied with the modules for troubleshooting information.

Replacing the Modular Power Supply

This section describes how to remove, configure, and install the PXI-1045 power-supply shuttle.



Caution Disconnect the power cable prior to replacing the power supply shuttle.

Before connecting the power-supply shuttle to a power source, read this section and the *Read Me First: Safety and Radio-Frequency Interference* document included with the kit.

Removal

The PXI-1045 power-supply shuttle is a replacement part for the PXI-1045 chassis. Before attempting to replace the power-supply shuttle, verify that there is adequate clearance behind the chassis. Set the power switch on the front panel to the Off (nonrecessed) position. Disconnect the power cable and any other cables from the power-supply shuttle on the rear of the chassis. Identify the 10 screws that attach the power-supply shuttle to the chassis. Refer to Figure 1-2, *Rear View of the PXI-1045 Chassis*, for the screw locations. Using a number 1 Phillips screwdriver, remove the screws. Pull on the two rear handles of the power-supply shuttle to remove it from the rear of the chassis.



Note The 10 power supply shuttle screws (4-40 × 1/4 in.) are not explicitly identified in Figure 1-2, *Rear View of the PXI-1045 Chassis*, but it can be used as a visual reference. The appropriate screws are located along the outer edges of the chassis' rear panel. There are six screws evenly spaced along the top and bottom edges, and four screws evenly spaced along the left and right edges.

Installation

Ensure that there is no visible damage to the new power-supply shuttle. Verify that the housing and connector on the new power-supply shuttle have no foreign material inside. Remove the protective cap on the internal 10 MHz REF connector (this is the connector that mates with the chassis backplane, not the BNC connectors on the rear panel). Install the new power-supply shuttle into the opening on the rear of the chassis. Insert and tighten the 10 screws with a Phillips screwdriver (maximum torque of 5 in. lbs).

Configuration

The fan-speed selector switch is on the rear panel of the power-supply shuttle. Refer to Figure 1-2, *Rear View of the PXI-1045 Chassis*, to locate the fan-speed selector. Select HIGH for maximum cooling performance (recommended) or AUTO for quieter operation. When set to AUTO, air-intake temperature determines the fan speed.

Connecting Safety Ground

Refer to the *Connecting Safety Ground* section of Chapter 2, *Installation and Configuration*.

Connecting to Power Source

Refer to the *Connecting to Power Source* section of Chapter 2, *Installation and Configuration*.

Specifications



Caution If the PXI-1045 chassis is used in a manner inconsistent with the instructions or specifications listed by National Instruments, the protective features of the chassis may be impaired.

This appendix contains specifications for the PXI-1045 chassis.

Electrical

AC Input

Input voltage range.....	100–240 VAC
Operating voltage range ¹	90–264 VAC
Input frequency	50/60 Hz
Operating frequency range ¹	47–63 Hz
Input current rating.....	10–5 A
Over-current protection.....	12 A circuit breaker
Line regulation	
3.3 V.....	<±1%
5 V.....	<±1%
±12 V	<±1%
Efficiency	70% minimum

¹ The operating range is guaranteed by design.

Power disconnect.....The AC power cable provides main power disconnect. Depressing the front-panel power switch controls the internal chassis power supply that provides DC power to the CompactPCI/PXI backplane. You can also use the rear-panel 9-pin D-sub connector to control the internal chassis power supply.

DC Output

DC current capacity (I_{MP})

Voltage	0–55°C
+3.3 V	40 A
+5 V	59 A
+12 V Peripheral slots	8.5 A
+12 V System slot	0.5 A
–12 V	4.5 A

Load regulation

Voltage	Load Regulation
+3.3 V	<0.5%
+12 V	<0.5%
+5 V	<0.5%
–12 V	<0.5%

Maximum ripple and noise (20 MHz bandwidth)

Voltage	Maximum Ripple and Noise
+3.3 V	50 mV _{pp}
+12 V	120 mV _{pp}
+5 V	50 mV _{pp}
-12 V	120 mV _{pp}

Over-current protection..... All outputs protected from short circuit and overload with automatic recovery when the short or overload is removed.

Over-voltage protection¹

3.3 V..... 140 to 150% above nominal output voltage

5 V, +12 V, -12 V..... 120 to 130% above nominal output voltage

Power-supply shuttle MTTR..... Replacement in under 5 minutes

Chassis Cooling

Per slot cooling capacity Slot cooling capacity is 25 W with fan speed set to HIGH

Slot airflow direction P1 to P2, bottom of module to top of module

Module cooling

System..... Forced air circulation (positive pressurization) through three 140 cfm fans with HIGH/AUTO speed selector

Intake Bottom rear of chassis

Exhaust..... Along both sides and top of chassis

¹ To reset over-voltage protection, remove the mains for 30 seconds and then power back up.

Power supply cooling

System	Forced air circulation through integrated fan
Intake	Right side of chassis
Exhaust	Left side of chassis

Safety

This product is designed to meet the requirements of the following standards of safety for electrical equipment for measurement, control, and laboratory use:

- IEC 61010-1, EN 61010-1
- UL 61010-1
- CAN/CSA-C22.2 No. 61010-1



Note For UL and other safety certifications, refer to the product label, or visit ni.com/certification, search by model number or product line, and click the appropriate link in the Certification column.

Electromagnetic Compatibility

EmissionsEN 55011 Class A at 10 m.
FCC Part 15A above 1 GHz

ImmunityEN 61326:1997 + A2:2001,
Table 1

CE, C-Tick, and FCC Part 15 (Class A) Compliant



Note For EMC compliance, operate this device with shielded cabling.

CE Compliance

This product meets the essential requirements of applicable European Directives, as amended for CE marking, as follows:

Low-Voltage Directive (safety).....73/23/EEC

Electromagnetic Compatibility
Directive (EMC)89/336/EEC



Note Refer to the Declaration of Conformity (DoC) for this product for any additional regulatory compliance information. To obtain the DoC for this product, visit ni.com/certification, search by model number or product line, and click the appropriate link in the Certification column.

Environmental

Operating temperature.....	0 to 55 °C
Storage temperature	–40 to 71 °C
Relative humidity	
Operating	10 to 90% non condensing
Nonoperational (storage)	5 to 95% non conducting
Shock	
Operational ^{1,2}	30 g peak, half sine, 11 ms pulse
Nonoperational ^{1,2}	30 g, half sine, 11 ms pulse
Operating location.....	Indoor use
Random vibration	
Operational ^{1,3}	5 to 500 Hz, 0.31 g _{RMS}
Nonoperational ^{1,3}	5 to 500 Hz, 2.46 g _{RMS}
Altitude.....	2,000 m
Installation Category	II
Pollution Degree	2

¹ Ambient temperature 25 °C.

² Tested in accordance with IEC-60068-2-27. Test profile developed in accordance with MIL-PRF-28800F.

³ Tested in accordance with IEC-60068-2-64. Nonoperating test profile developed in accordance with MIL-PRF-28800F and MIL-STD-810E Method 514.

Backplane

Size	3U-sized; one system slot (with three system expansion slots) and 17 peripheral slots. Compliant with IEEE 1101.10 mechanical packaging. PXI Hardware Specification, Revision 2.2 compliant. Accepts both PXI and CompactPCI (PICMG 2.0 R 3.0) 3U modules.
V(I/O) ¹	+5 V
Backplane bare-board material	UL 94 V-0 Recognized
Backplane connectors	Conforms to IEC 917 and IEC 1076-4-101, and are UL 94 V-0 rated

10 MHz System Reference Clock (10 MHz REF)

Maximum clock skew between slots.....	250 ps
Built-in 10 MHz clock	
Accuracy	±25 ppm (guaranteed over the operating temperature range)
Maximum jitter.....	5 ps RMS in 10 Hz to 1 MHz range
External clock sources	
Connectors	BNC on rear of chassis (ground referenced) or slot 2 J2 (pin D17; refer to Table B-4, <i>P2 (J2) Connector Pinout for the Star Trigger Slot</i>)

¹ V(I/O) is connected to the +5 V DC power plane, so the same specs apply to V(I/O) and +5 V.

Input frequency	10 MHz \pm 100 ppm or better
Input amplitude	
Rear connector	200 mV _{pp} to 5 V _{pp} , 10 MHz squarewave or sinewave
Slot 2.....	5 V or 3.3 V, 10 MHz TTL signal
Input impedance.....	50 Ω \pm 5 Ω (rear connector)
Maximum jitter introduced by backplane circuitry.....	1 ps RMS in 10 Hz to 1 MHz range
External clock output	
Connector.....	BNC on rear of chassis (ground-referenced)
Output amplitude	1 V _{pp} \pm 20% squarewave into 50 Ω 2 V _{pp} into open circuit
Output impedance	50 Ω \pm 5 Ω

Mechanical

Overall dimensions (standard chassis)

Height..... 177 mm (6.97 in.)



Note 14.5 mm (0.57 in.) is added to height when feet are installed. When tilted with front feet extended on table top, height is increased approximately 52.8 mm (2.08 in.) in front and 14.8 mm (0.583 in.) in rear.

Width

Depth.....

Weight.....

Chassis materials..... Sheet Aluminum (5052-H32, 3003-H14, and 6061-T6), Extruded Aluminum (6060-T6), Cold Rolled Steel, PC-ABS, Santoprene, Nylon

Finish..... Conductive Clear Iridite on Aluminum
Clear Chromate Zinc Plating on Cold Rolled Steel
Polyurethane Enamel

Figures A-1 and A-2 show the PXI-1045 dimensions. The holes shown are for the installation of the optional rack-mount kits as shown in Figure A-3. Notice that the front and rear rack mounting holes (size M4) are symmetrical.

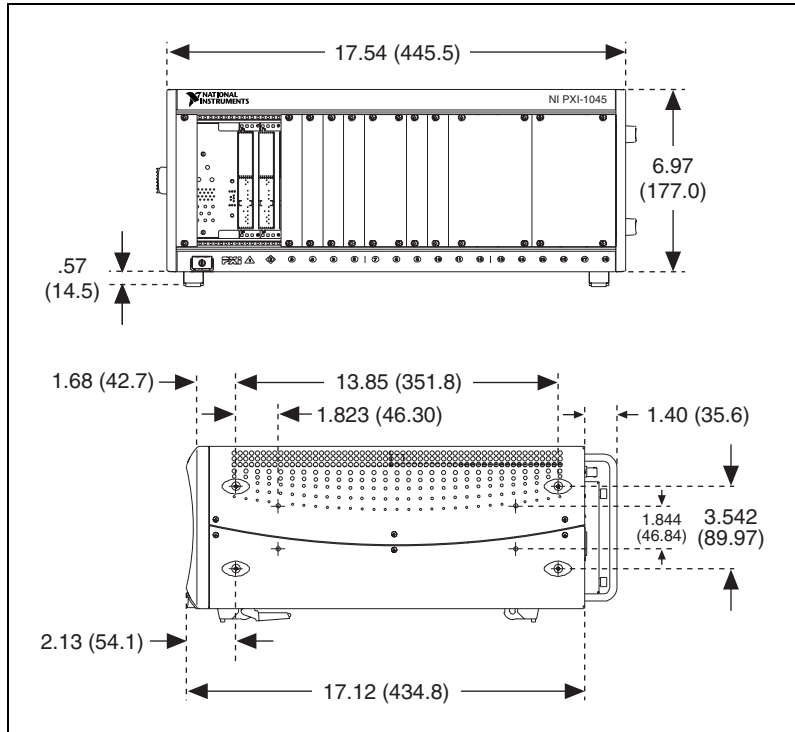

Figure A-1. PXI-1045 Dimensions (Front and Side) in Inches (mm)

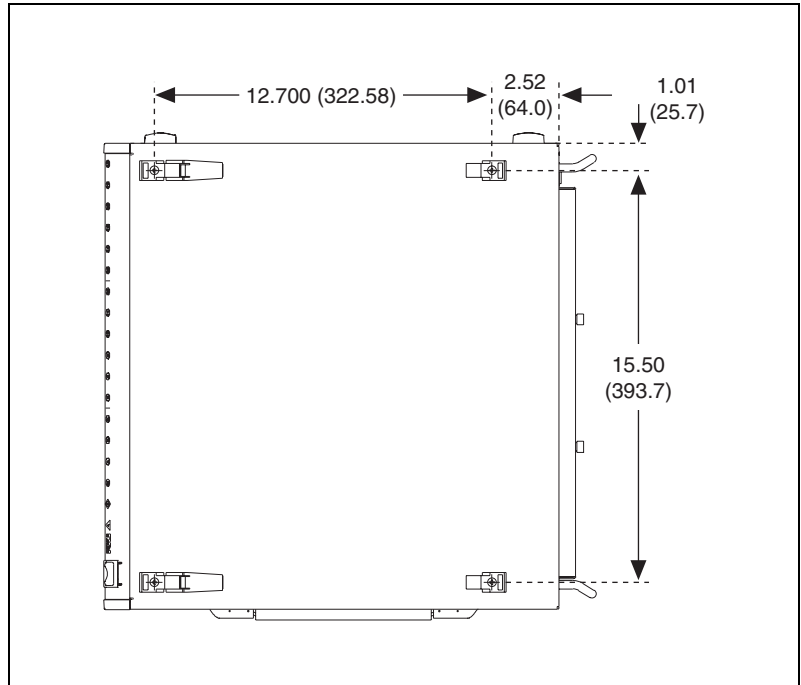

Figure A-2. PXI-1045 Dimensions (Bottom) in Inches (mm)

Figure A-3 shows the PXI-1045 rack-mount kit components.

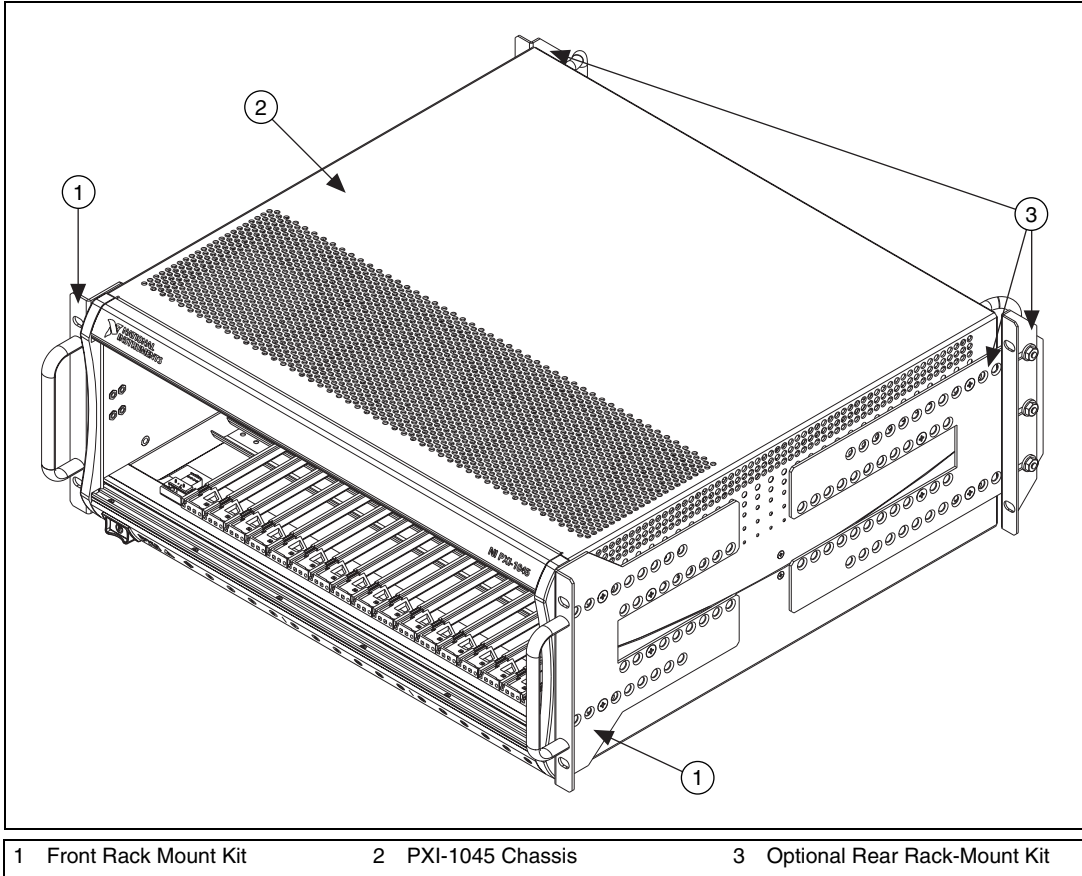

Figure A-3. PXI-1045 Rack Mount Kit Components

Pinouts

This appendix describes the P1 and P2 connector pinouts for the PXI-1045 backplane.

Table B-1 shows the P1 (J1) connector pinout for the System Controller slot.

Table B-2 shows the P2 (J2) connector pinout for the System Controller slot.

Table B-3 shows the P1 (J1) connector pinout for the star trigger slot.

Table B-4 shows the P2 (J2) connector pinout for the star trigger slot.

Table B-5 shows the P1 (J1) connector pinout for the peripheral slots.

Table B-6 shows the P2 (J2) connector pinout for the peripheral slots.



Note PXI signals are shown in bold.

For more detailed information, refer to the *PXI Hardware Specification, Revision 2.2*. Contact the PXI Systems Alliance for a copy of the specification or visit www.pxisa.org.

Table B-1. P1 (J1) Connector Pinout for the System Controller Slot

Pin	Z	A	B	C	D	E	F
25	GND	5V	REQ64#	ENUM#	3.3V	5V	GND
24	GND	AD[1]	5V	V(I/O)	AD[0]	ACK64#	GND
23	GND	3.3V	AD[4]	AD[3]	5V	AD[2]	GND
22	GND	AD[7]	GND	3.3V	AD[6]	AD[5]	GND
21	GND	3.3V	AD[9]	AD[8]	M66EN	C/BE[0]#	GND
20	GND	AD[12]	GND	V(I/O)	AD[11]	AD[10]	GND
19	GND	3.3V	AD[15]	AD[14]	GND	AD[13]	GND
18	GND	SERR#	GND	3.3V	PAR	C/BE[1]#	GND
17	GND	3.3V	IPMB_SCL	IPMB_SDA	GND	PERR#	GND
16	GND	DEVSEL#	GND	V(I/O)	STOP#	LOCK#	GND
15	GND	3.3V	FRAME#	IRDY#	GND	TRDY#	GND
12–14	Key Area						
11	GND	AD[18]	AD[17]	AD[16]	GND	C/BE[2]#	GND
10	GND	AD[21]	GND	3.3V	AD[20]	AD[19]	GND
9	GND	C/BE[3]#	GND	AD[23]	GND	AD[22]	GND
8	GND	AD[26]	GND	V(I/O)	AD[25]	AD[24]	GND
7	GND	AD[30]	AD[29]	AD[28]	GND	AD[27]	GND
6	GND	REQ0#	GND	3.3V	CLK0	AD[31]	GND
5	GND	BRSVP1A5	BRSVP1B5	RST#	GND	GNT0#	GND
4	GND	IPMB_PWR	HEALTHY	V(I/O)	INTP	INTS	GND
3	GND	INTA#	INTB#	INTC#	5V	INTD#	GND
2	GND	TCK	5V	TMS	TDO	TDI	GND
1	GND	5V	-12V	TRST#	+12V	5V	GND

Table B-2. P2 (J2) Connector Pinout for the System Controller Slot

Pin	Z	A	B	C	D	E	F
22	GND	GA4	GA3	GA2	GA1	GA0	GND
21	GND	CLK6	GND	RSV	RSV	RSV	GND
20	GND	CLK5	GND	RSV	GND	RSV	GND
19	GND	GND	GND	SMB_SDA	SMB_SCL	SMB_ALERT#	GND
18	GND	PXI_TRIG3	PXI_TRIG4	PXI_TRIG5	GND	PXI_TRIG6	GND
17	GND	PXI_TRIG2	GND	PRST#	REQ6#	GNT6#	GND
16	GND	PXI_TRIG1	PXI_TRIG0	DEG#	GND	PXI_TRIG7	GND
15	GND	PXI_BRSVA15	GND	FAL#	REQ5#	GNT5#	GND
14	GND	BP(I/O)	BP(I/O)	BP(I/O)	GND	BP(I/O)	GND
13	GND	BP(I/O)	GND	V(I/O)	BP(I/O)	BP(I/O)	GND
12	GND	BP(I/O)	BP(I/O)	BP(I/O)	GND	BP(I/O)	GND
11	GND	BP(I/O)	GND	V(I/O)	BP(I/O)	BP(I/O)	GND
10	GND	BP(I/O)	BP(I/O)	BP(I/O)	GND	BP(I/O)	GND
9	GND	BP(I/O)	GND	V(I/O)	BP(I/O)	BP(I/O)	GND
8	GND	BP(I/O)	BP(I/O)	BP(I/O)	GND	BP(I/O)	GND
7	GND	BP(I/O)	GND	V(I/O)	BP(I/O)	BP(I/O)	GND
6	GND	BP(I/O)	BP(I/O)	BP(I/O)	GND	BP(I/O)	GND
5	GND	BP(I/O)	64EN#	V(I/O)	BP(I/O)	BP(I/O)	GND
4	GND	V(I/O)	PXI_BRSVB4	BP(I/O)	GND	BP(I/O)	GND
3	GND	CLK4	GND	GNT3#	REQ4#	GNT4#	GND
2	GND	CLK2	CLK3	SYSEN#	GNT2#	REQ3#	GND
1	GND	CLK1	GND	REQ1#	GNT1#	REQ2#	GND

Table B-3. P1 (J1) Connector Pinout for the Star Trigger Slot

Pin	Z	A	B	C	D	E	F
25	GND	5V	REQ64#	ENUM#	3.3V	5V	GND
24	GND	AD[1]	5V	V(I/O)	AD[0]	ACK64#	GND
23	GND	3.3V	AD[4]	AD[3]	5V	AD[2]	GND
22	GND	AD[7]	GND	3.3V	AD[6]	AD[5]	GND
21	GND	3.3V	AD[9]	AD[8]	M66EN	C/BE[0]#	GND
20	GND	AD[12]	GND	V(I/O)	AD[11]	AD[10]	GND
19	GND	3.3V	AD[15]	AD[14]	GND	AD[13]	GND
18	GND	SERR#	GND	3.3V	PAR	C/BE[1]#	GND
17	GND	3.3V	IPMB_SCL	IPMB_SDA	GND	PERR#	GND
16	GND	DEVSEL#	GND	V(I/O)	STOP#	LOCK#	GND
15	GND	3.3V	FRAME#	IRDY#	BD_SEL#	TRDY#	GND
12–14	Key Area						
11	GND	AD[18]	AD[17]	AD[16]	GND	C/BE[2]#	GND
10	GND	AD[21]	GND	3.3V	AD[20]	AD[19]	GND
9	GND	C/BE[3]#	IDSEL	AD[23]	GND	AD[22]	GND
8	GND	AD[26]	GND	V(I/O)	AD[25]	AD[24]	GND
7	GND	AD[30]	AD[29]	AD[28]	GND	AD[27]	GND
6	GND	REQ#	GND	3.3V	CLK	AD[31]	GND
5	GND	BRSVP1A5	BRSVP1B5	RST#	GND	GNT#	GND
4	GND	IPMB_PWR	HEALTHY	V(I/O)	INTP	INTS	GND
3	GND	INTA#	INTB#	INTC#	5V	INTD#	GND
2	GND	TCK	5V	TMS	TDO	TDI	GND
1	GND	5V	-12V	TRST#	+12V	5V	GND

Table B-4. P2 (J2) Connector Pinout for the Star Trigger Slot

Pin	Z	A	B	C	D	E	F
22	GND	GA4	GA3	GA2	GA1	GA0	GND
21	GND	PXI_LBR0	RSV	PXI_LBR1	PXI_LBR2	PXI_LBR3	GND
20	GND	PXI_LBR4	PXI_LBR5	PXI_STAR0	GND	PXI_STAR1	GND
19	GND	PXI_STAR2	RSV	PXI_STAR3	PXI_STAR4	PXI_STAR5	GND
18	GND	PXI_TRIG3	PXI_TRIG4	PXI_TRIG5	GND	PXI_TRIG6	GND
17	GND	PXI_TRIG2	GND	RSV	PXI_CLK10_IN	PXI_CLK10	GND
16	GND	PXI_TRIG1	PXI_TRIG0	RSV	GND	PXI_TRIG7	GND
15	GND	PXI_BRSVA15	GND	RSV	PXI_STAR6	PXI_LBR6	GND
14	GND	RSV	RSV	RSV	GND	RSV	GND
13	GND	RSV	GND	V(I/O)	RSV	RSV	GND
12	GND	RSV	RSV	RSV	GND	RSV	GND
11	GND	RSV	GND	V(I/O)	RSV	RSV	GND
10	GND	RSV	RSV	RSV	GND	RSV	GND
9	GND	RSV	GND	V(I/O)	RSV	RSV	GND
8	GND	RSV	RSV	RSV	GND	RSV	GND
7	GND	RSV	GND	V(I/O)	RSV	RSV	GND
6	GND	RSV	RSV	RSV	GND	RSV	GND
5	GND	RSV	64EN#	V(I/O)	RSV	RSV	GND
4	GND	V(I/O)	PXI_BRSVB4	RSV	GND	RSV	GND
3	GND	PXI_LBR7	GND	PXI_LBR8	PXI_LBR9	PXI_LBR10	GND
2	GND	PXI_LBR11	PXI_LBR12	UNC	PXI_STAR7	PXI_STAR8	GND
1	GND	PXI_STAR9	GND	PXI_STAR10	PXI_STAR11	PXI_STAR12	GND

Table B-5. P1 (J1) Connector Pinout for the Generic Peripheral Slot

Pin	Z	A	B	C	D	E	F
25	GND	5V	REQ64#	ENUM#	3.3V	5V	GND
24	GND	AD[1]	5V	V(I/O)	AD[0]	ACK64#	GND
23	GND	3.3V	AD[4]	AD[3]	5V	AD[2]	GND
22	GND	AD[7]	GND	3.3V	AD[6]	AD[5]	GND
21	GND	3.3V	AD[9]	AD[8]	M66EN	C/BE[0]#	GND
20	GND	AD[12]	GND	V(I/O)	AD[11]	AD[10]	GND
19	GND	3.3V	AD[15]	AD[14]	GND	AD[13]	GND
18	GND	SERR#	GND	3.3V	PAR	C/BE[1]#	GND
17	GND	3.3V	IPMB_SCL	IPMB_SDA	GND	PERR#	GND
16	GND	DEVSEL#	GND	V(I/O)	STOP#	LOCK#	GND
15	GND	3.3V	FRAME#	IRDY#	BD_SEL#	TRDY#	GND
12–14	Key Area						
11	GND	AD[18]	AD[17]	AD[16]	GND	C/BE[2]#	GND
10	GND	AD[21]	GND	3.3V	AD[20]	AD[19]	GND
9	GND	C/BE[3]#	IDSEL	AD[23]	GND	AD[22]	GND
8	GND	AD[26]	GND	V(I/O)	AD[25]	AD[24]	GND
7	GND	AD[30]	AD[29]	AD[28]	GND	AD[27]	GND
6	GND	REQ#	GND	3.3V	CLK	AD[31]	GND
5	GND	BRSVP1A5	BRSVP1B5	RST#	GND	GNT#	GND
4	GND	IPMB_PWR	HEALTHY	V(I/O)	INTP	INTS	GND
3	GND	INTA#	INTB#	INTC#	5V	INTD#	GND
2	GND	TCK	5V	TMS	TDO	TDI	GND
1	GND	5V	-12V	TRST#	+12V	5V	GND

Table B-6. P2 (J2) Connector Pinout for the Generic Peripheral Slot

Pin	Z	A	B	C	D	E	F
22	GND	GA4	GA3	GA2	GA1	GA0	GND
21	GND	PXI_LBR0	RSV	PXI_LBR1	PXI_LBR2	PXI_LBR3	GND
20	GND	PXI_LBR4	PXI_LBR5	PXI_LBL0	GND	PXI_LBL1	GND
19	GND	PXI_LBL2	RSV	PXI_LBL3	PXI_LBL4	PXI_LBL5	GND
18	GND	PXI_TRIG3	PXI_TRIG4	PXI_TRIG5	GND	PXI_TRIG6	GND
17	GND	PXI_TRIG2	GND	RSV	PXI_STAR	PXI_CLK10	GND
16	GND	PXI_TRIG1	PXI_TRIG0	RSV	GND	PXI_TRIG7	GND
15	GND	PXI_BRSVA15	GND	RSV	PXI_LBL6	PXI_LBR6	GND
14	GND	RSV	RSV	RSV	GND	RSV	GND
13	GND	RSV	GND	V(I/O)	RSV	RSV	GND
12	GND	RSV	RSV	RSV	GND	RSV	GND
11	GND	RSV	GND	V(I/O)	RSV	RSV	GND
10	GND	RSV	RSV	RSV	GND	RSV	GND
9	GND	RSV	GND	V(I/O)	RSV	RSV	GND
8	GND	RSV	RSV	RSV	GND	RSV	GND
7	GND	RSV	GND	V(I/O)	RSV	RSV	GND
6	GND	RSV	RSV	RSV	GND	RSV	GND
5	GND	RSV	64EN#	V(I/O)	RSV	RSV	GND
4	GND	V(I/O)	PXI_BRSVB4	RSV	GND	RSV	GND
3	GND	PXI_LBR7	GND	PXI_LBR8	PXI_LBR9	PXI_LBR10	GND
2	GND	PXI_LBR11	PXI_LBR12	UNC	PXI_LBL7	PXI_LBL8	GND
1	GND	PXI_LBL9	GND	PXI_LBL10	PXI_LBL11	PXI_LBL12	GND



Technical Support and Professional Services

Visit the following sections of the National Instruments Web site at ni.com for technical support and professional services:

- **Support**—Online technical support resources at ni.com/support include the following:
 - **Self-Help Resources**—For answers and solutions, visit the award-winning National Instruments Web site for software drivers and updates, a searchable KnowledgeBase, product manuals, step-by-step troubleshooting wizards, thousands of example programs, tutorials, application notes, instrument drivers, and so on.
 - **Free Technical Support**—All registered users receive free Basic Service, which includes access to hundreds of Application Engineers worldwide in the NI Developer Exchange at ni.com/exchange. National Instruments Application Engineers make sure every question receives an answer.

For information about other technical support options in your area, visit ni.com/services or contact your local office at ni.com/contact.

- **Training and Certification**—Visit ni.com/training for self-paced training, eLearning virtual classrooms, interactive CDs, and Certification program information. You also can register for instructor-led, hands-on courses at locations around the world.
- **System Integration**—If you have time constraints, limited in-house technical resources, or other project challenges, National Instruments Alliance Partner members can help. To learn more, call your local NI office or visit ni.com/alliance.

If you searched ni.com and could not find the answers you need, contact your local office or NI corporate headquarters. Phone numbers for our worldwide offices are listed at the front of this manual. You also can visit the Worldwide Offices section of ni.com/niglobal to access the branch office Web sites, which provide up-to-date contact information, support phone numbers, email addresses, and current events.

Glossary

Symbol	Prefix	Value
p	pico	10^{-12}
n	nano	10^{-9}
μ	micro	10^{-6}
m	milli	10^{-3}
k	kilo	10^3
M	mega	10^6
G	giga	10^9
T	tera	10^{12}

Symbols

°	Degrees.
≥	Equal or greater than.
≤	Equal or less than.
%	Percent.
Ω	Ohms.

A

A	Amperes.
AC	Alternating current.
ANSI	American National Standards Institute.
AUTO	Automatic fan speed control.
AWG	American Wire Gauge.

B

backplane An assembly, typically a printed circuit board, with connectors and signal paths that bus the connector pins.

BNC Bayonet Neill Concelman connector; a commonly used coaxial connector.

C

C Celsius.

cfm Cubic feet per minute.

CFR Code of Federal Regulations.

cm Centimeters.

CompactPCI An adaptation of the Peripheral Component Interconnect (PCI) Specification 2.1 or later for industrial and/or embedded applications requiring a more robust mechanical form factor than desktop PCI. It uses industry standard mechanical components and high-performance connector technologies to provide an optimized system intended for rugged applications. It is electrically compatible with the PCI Specification, which enables low-cost PCI components to be utilized in a mechanical form factor suited for rugged environments.

CSA Canadian Standards Association.

D

daisy-chain A method of propagating signals along a bus, in which the devices are prioritized on the basis of their position on the bus.

DB-9 A 9-pin D-sub connector.

DC Direct current.

DoC Declaration of Conformity.

D-sub Subminiature D connector.

E

efficiency	Ratio of output power to input power, expressed as a percentage.
EIA	Electronic Industries Association.
EMC	Electromagnetic Compatibility.
EMI	Electromagnetic Interference.
Embedded system controller	A module configured for installation in slot 1 of a PXI chassis. This device is unique in the PXI system in that it performs the system controller functions, including clock sourcing and arbitration for data transfers across the backplane. Installing such a device into any other slot can damage the device, the PXI backplane, or both.

F

FCC	Federal Communications Commission.
filler panel	A blank module front panel used to fill empty slots in the chassis.

G

g	(1) grams; (2) a measure of acceleration approximately equal to 9.8 m/s^2 .
GPIB	General Purpose Interface Bus (IEEE 488).
g_{RMS}	A measure of random vibration. The root mean square of acceleration levels in a random vibration test profile.

H

hr	Hours.
Hz	Hertz; cycles per second.

I

IEC	International Electrotechnical Commission; an organization that sets international electrical and electronics standards.
IEEE	Institute of Electrical and Electronics Engineers.
I_{MP}	Mainframe peak current.
in.	Inches.
inhibit	To turn off.

J

jitter	A measure of the small, rapid variations in clock transition times from their nominal regular intervals. Units: seconds RMS.
--------	--

K

kg	Kilograms.
km	Kilometers.

L

lb	Pounds.
LED	Light emitting diode.
line regulation	The maximum steady-state percentage that a DC voltage output will change as a result of a specified change in input AC voltage (step change from 90 to 132 VAC or 180 to 264 VAC).
load regulation	The maximum steady-state percentage that a DC voltage output will change as a result of a step change from no-load to full-load output current.

M

m	Meters.
MAX	NI Measurement & Automation Explorer, the utility which allows you to configure and test your PXI system.
MHz	Megahertz. One million Hertz; one Hertz equals one cycle per second.
ms	Millisecond, one thousandth of a second (10^{-3}).
MTBF	Mean time between failure.
MTTR	Mean time to repair.

N

NEMA	National Electrical Manufacturers Association.
NI	National Instruments.
NI-DAQmx	National Instruments driver which controls the operation of National Instruments data acquisition (DAQ) devices.
NI-VISA	National Instruments' implementation of the VISA (Virtual Instrument System Architecture) I/O standard. NI-VISA provides support for the VISA API, and also provides VISAIC, a utility for instrument configuration and I/O function execution.
ns	Nanosecond, one billionth of a second (10^{-9}).

P

ppm	Parts-per-million.
power-supply shuttle	A removable module that contains the chassis power supply.
ps	Picosecond, one trillionth of a second (10^{-12}).

PXI PCI eXtensions for Instrumentation. PXI is an implementation of CompactPCI with added electrical features that meet the high performance requirements of instrumentation applications by providing triggering, local buses, and system clock capabilities.

PXI_CLK10 10 MHz PXI system reference clock.

R

RMS Root mean square.

S

s Seconds.

skew Deviation in signal transmission times.

slot blocker An assembly installed into an empty slot to improve the airflow in adjacent slots.

ST Star trigger.

standby The backplane is unpowered (off), but the chassis is still connected to AC power mains.

star trigger slot This slot is located at slot 2 and has a dedicated trigger line between each peripheral slot. Use this slot for a module with ST functionality that can provide individual triggers to all other peripherals.

system reference clock A 10 MHz clock, also called PXI_CLK10, that is distributed to all peripheral slots in the chassis, as well as a BNC connector on the rear of chassis labeled *10 MHz REF OUT*. The system reference clock can be used for synchronization of multiple modules in a measurement or control system. The 10 MHz REF IN and OUT BNC connectors on the rear of the chassis can be used to synchronize multiple chassis to one reference clock. The PXI backplane specification defines implementation guidelines for PXI_CLK10.

T

TTL Transistor-transistor logic.

U

UL Underwriter's Laboratories.

V

V Volts.

VAC Volts alternating current, or V_{rms} .

V_{pp} Peak-to-peak voltage.

W

W Watts.

Index

A

AC power cables (table), 1-2

B

backplane

- interoperability with CompactPCI, 1-5
- local bus, 1-6
- overview, 1-5
- peripheral slots, 1-6
- specifications, A-6
- star trigger (ST) slot, 1-6
- system reference clock, 1-8
- trigger bus, 1-8

C

- cables, power (table), 1-2
- chassis initialization file, 2-14
- CLK10 rear connectors, 2-11
- CompactPCI
 - installing modules (figure), 2-8
 - interoperability with PXI-1045
 - backplane, 1-5
- configuration. *See* installation, configuration, and operation
- connector pinouts. *See* pinouts
- conventions used in the manual, *vii*
- cooling
 - air cooling of PXI-1045, 2-2
 - air intake (figure), 2-3
 - filler panel installation, 2-3
 - setting fan speed, 2-3
 - slot blocker installation, 2-3

D

- diagnostic tools (NI resources), C-1
- dimensions (figure), A-8, A-9
- documentation
 - conventions used in manual, *vii*
 - NI resources, C-1
 - related documentation, *viii*
- drivers (NI resources), C-1
- D-sub connector
 - pinout (table), 2-9
 - power supply voltages (table), 2-10

E

- electromagnetic compatibility, A-4
- EMC filler panel kit, 1-4
- examples (NI resources), C-1

F

- fan, setting speed, 2-3
- filler panel installation, 2-3

G

- ground, connecting, 2-4

H

- help, technical support, C-1

I

- installation, configuration, and operation
 - chassis initialization file, 2-14
 - configuration in MAX (figure), 2-12
 - connecting safety ground, 2-4

- filler panel installation, 2-3
- installing a PXI controller, 2-5
- module installation, 2-6, 2-7
 - CompactPCI or PXI modules (figure), 2-8
 - injector/ejector handle position (figure), 2-6
- PXI configuration in MAX, 2-11
 - trigger configuration, 2-13
- PXI controller installed in a PXI-1045 chassis (figure), 2-7
- rack mounting, 2-4
- remote voltage monitoring and inhibiting connector, 2-9
- setting fan speed, 2-3
- site considerations, 2-2
- slot blocker installation, 2-3
- testing power up, 2-4
- unpacking the PXI-1045, 1-1
- instrument drivers (NI resources), C-1
- interoperability with CompactPCI, 1-5

K

- key features, 1-2
- kit contents, 1-1
- KnowledgeBase, C-1

L

- local bus, routing (figure), 1-6, 1-7

M

- maintenance of PXI-1045
 - cleaning
 - exterior cleaning, 3-2
 - fan filters, 3-2
 - interior cleaning, 3-2
 - preparation, 3-1

- resetting the AC mains circuit breaker, 3-3
- service interval, 3-1
- static discharge damage (caution), 3-1

N

- National Instruments support and services, C-1

O

- optional equipment, 1-4

P

- P1 (J1) connector
 - peripheral slot (table), B-6
 - star trigger slot (table), B-4
 - system controller slot (table), B-2
- P2 (J2) connector
 - peripheral slot (table), B-7
 - star trigger slot (table), B-5
 - system controller slot (table), B-3
- peripheral slots
 - overview, 1-6
 - P1 (J1) connector pinouts (table), B-6
 - P2 (J2) connector pinouts (table), B-7
- pinouts, B-1
 - D-sub connector (table), 2-9
 - P1 (J1) connector
 - peripheral slot (table), B-6
 - star trigger slot (table), B-4
 - system controller slot (table), B-2
 - P2 (J2) connector
 - peripheral slot (table), B-7
 - star trigger slot (table), B-5
 - system controller slot (table), B-3
- power cables (table), 1-2

- power supply
 - connecting to, 2-4
 - remote voltage monitoring and inhibiting connector, 2-9
 - replacing
 - configuration, 3-4
 - connecting safety ground, 3-5
 - connecting to power source, 3-5
 - installation, 3-4
 - removal, 3-4
 - voltages at voltage monitoring connector (D-sub) (table), 2-9
- power switch LED indicator, 2-8
- power up, testing, 2-4
- programming examples (NI resources), C-1
- PXI controller, 2-5
 - installing in a PXI-1045 chassis (figure), 2-7
- PXI_CLK10, 1-8
- PXI_CLK10_IN pin, 1-8
- PXI-1045
 - cooling air intake (figure), 2-3
 - fan speed, setting, 2-3
 - front view (figure), 1-3
 - installation. *See* installation, configuration, and operation
 - key features, 1-2
 - maintenance. *See* maintenance of PXI-1045
 - optional equipment, 1-4
 - rack mounting, 2-4
 - rack-mount kits, 1-4
 - rear view of chassis, 1-4
 - safety ground, connecting, 2-4
- PXI-1045 backplane
 - interoperability with CompactPCI, 1-5
 - local bus, 1-6
 - overview, 1-5
 - peripheral slots, 1-6
 - specifications, A-6
 - star trigger (ST) slot, 1-6

- system reference clock, 1-8
- trigger bus, 1-8

R

- rack mount kit dimensions (figure), A-10
- rack mounting, 2-4
- rack-mount kits, 1-4
- related documentation, *viii*
- remote voltage monitoring and inhibiting connector
 - pinout (table), 2-9
 - power supply voltages (table), 2-10

S

- safety and caution notices, 2-1
- safety ground, connecting, 2-4
- safety specifications (table), A-4
- service interval, 3-1
- setting fan speed, 2-3
- slot blocker
 - installation, 2-3
 - kit, 1-4
- software (NI resources), C-1
- specifications
 - backplane, A-6
 - chassis cooling, A-3
 - dimensions (figure), A-8, A-9
 - electrical
 - AC input, A-1
 - DC output, A-2
 - electromagnetic compatibility, A-4
 - environmental, A-5
 - mechanical, A-7
 - rack mount kit dimensions (figure), A-10
 - safety, A-4
- star trigger (ST) slot
 - description, 1-6
 - P1 (J1) connector pinouts (table), B-4
 - P2 (J2) connector pinouts (table), B-5

support, technical, C-1
system controller slot
 description, 1-5
 P1 (J1) connector pinouts (table), B-2
 P2 (J2) connector pinouts (table), B-3
system reference clock, 1-8

T

technical support, C-1
testing power up, 2-4
training and certification (NI resources), C-1
trigger bus, 1-8
troubleshooting (NI resources), C-1

U

unpacking the PXI-1045, 1-1

V

voltage monitoring connector. *See* D-sub connector
voltages at voltage monitoring connector (D-sub) (table), 2-10

W

Web resources, C-1