

USER GUIDE AND SPECIFICATIONS

USB-9211/9211A

4-Channel, 24-Bit Thermocouple Input Devices

This user guide describes how to use the National Instruments USB-9211/9211A devices and lists the specifications.

Contents

Introduction	2
Safety Guidelines	2
Safety Guidelines for Hazardous Voltages	3
Software	3
Related Documentation.....	4
Installing the USB-9211/9211A Device	4
Installing the Software	4
Installing the NI USB-9211/9211A in the USB-9161/9162 Carrier	4
Mounting the USB-9211/9211A to a Panel.....	6
Connecting the USB-9211/9211A to a Computer	6
LED Indicator	6
Wiring the USB-9211/9211A	7
Assembling the High Voltage Screw Terminal Backshell	8
USB-9211/9211A Circuitry	9
Effects of Source Impedance on Voltage Measurement Accuracy	9
Determining Temperature Measurement Accuracy and Minimizing Errors.....	10
Using the Autozero Channel.....	10
Measurement Accuracy for the Different Types of Thermocouples	11
Cold-Junction Temperature Measurement Accuracy	13
Minimizing Thermal Gradients	14
Specifications	14
Input Characteristics	14
Power Requirements	16
Bus Interface	16

Physical Characteristics.....	16
Safety.....	16
Standards.....	16
Voltages.....	17
Environmental.....	17
Electromagnetic Compatibility.....	18
CE Compliance.....	18
Calibration.....	18
Where to Go for Support.....	19

Introduction

The NI USB-9211/9211A data acquisition device provides a USB interface for four channels of 24-bit thermocouple inputs with integrated signal conditioning.

The NI USB-9211 consists of two components: an NI 9211 module and a USB-9161 carrier, as shown in Figure 1. The NI USB-9211A consists of two components: an NI 9211 module and a USB-9162 carrier, as shown in Figure 1.

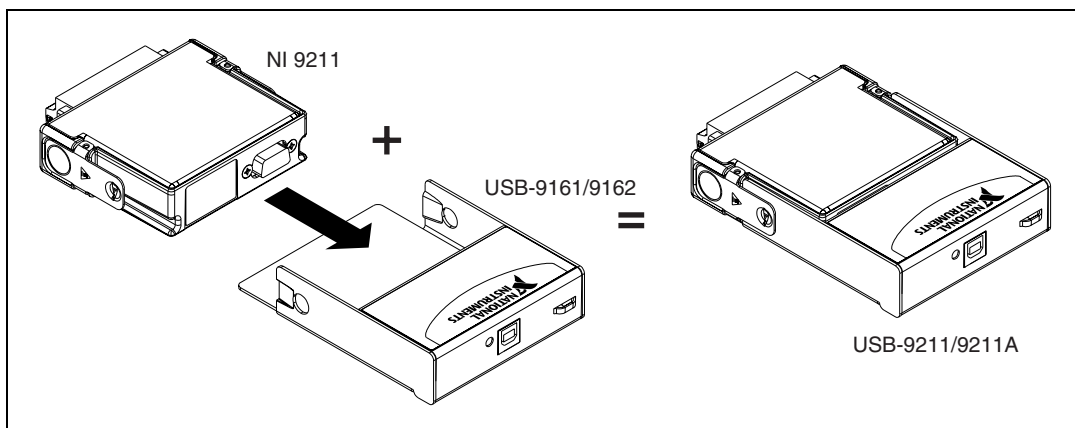

Figure 1. USB-9211/9211A Components

Safety Guidelines

Operate the USB-9211/9211A only as described in these operating instructions.



Note Although the NI 9211 module may have more stringent certification standards than the USB-9211/9211A, when used with the USB-9161/9162 carrier, the combined system may be limited. Refer to the [Specifications](#) section for more details.



Hot Surface This icon denotes that the component may be hot. Touching this component may result in bodily injury.



Caution Do *not* disconnect I/O-side wires or connectors unless power has been switched off or the area is known to be nonhazardous.



Caution Do *not* remove modules unless power has been switched off or the area is known to be nonhazardous.



Caution The USB-9211/9211A is *not* certified for use in hazardous locations.

Safety Guidelines for Hazardous Voltages

If *hazardous voltages* are connected to the module, take the following precautions. A hazardous voltage is a voltage greater than 42.4 V_{pk} or 60 VDC to earth ground.



Caution Ensure that hazardous voltage wiring is performed only by qualified personnel adhering to local electrical standards.



Caution Do *not* mix hazardous voltage circuits and human-accessible circuits on the same module.



Caution Make sure that devices and circuits connected to the module are properly insulated from human contact.



Caution When module terminals are live with hazardous voltages, make sure that the terminals are not accessible by using the high voltage screw terminal enclosure. Refer to the [Assembling the High Voltage Screw Terminal Backshell](#) section for more information.

Software

Software support for your hardware depends on the carrier being used. Refer to Table 1 for a list of software support.

Table 1. Devices and Corresponding Components

Device	Carrier	Software Support
USB-9211	NI 9161	NI-DAQmx Base
USB-9211A	NI 9162	NI-DAQmx

Examples are included with each software API. Refer to the corresponding software Getting Started Guide for more information.

Related Documentation

Guide	Location
<i>NI-DAQmx Getting Started Guide</i>	Accessible from Start»All Programs»National Instruments»NI-DAQ after install.
<i>NI-DAQmx for USB Devices Getting Started Guide</i>	Ships with your device and, after install, is accessible from Start»All Programs»National Instruments»NI-DAQ .
<i>NI-DAQmx Base Getting Started Guide</i>	Accessible from Start»All Programs»National Instruments»NI-DAQmx Bases»Documentation after install.

If your device uses NI-DAQmx Base, refer to ni.com to download the software.

Installing the USB-9211/9211A Device

Installing the Software

Before installing the device, you must install the software you plan to use with the device. Refer to the [Software](#) section of this manual and the documentation included with the software for more information.

Installing the NI USB-9211/9211A in the USB-9161/9162 Carrier

The NI 9211 module and the USB-9161/9162 carrier are packaged separately. Refer to Figure 2, while completing the following assembly steps:

1. Make sure that no signals are connected to the NI 9211 module and the USB cable is not connected to the device.
2. Remove the protective cover from the 15-pin DSUB connector.

3. Align the I/O module with the carrier, as shown in Figure 2.

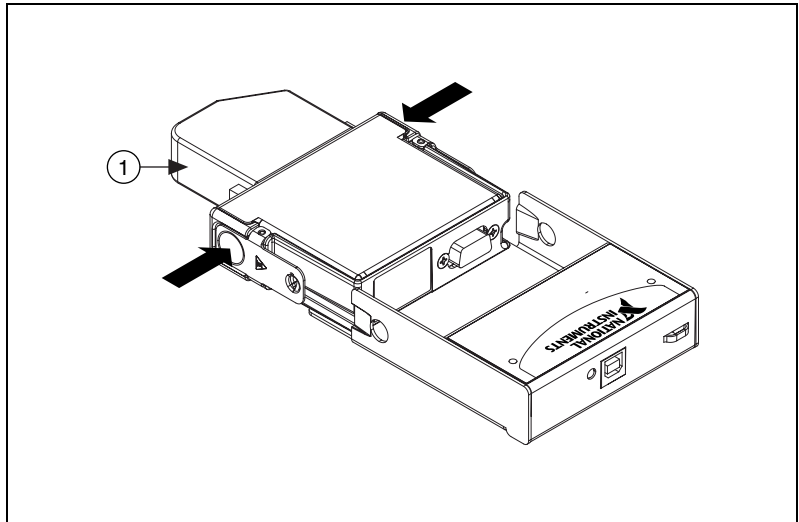

1 High Voltage Screw Terminal Backshell

Figure 2. Module Installation

4. Squeeze the latches and insert the NI 9211 module into the carrier.
5. Press firmly on the connector side of the NI 9211 module until the latches lock the module into place, as shown in Figure 3.

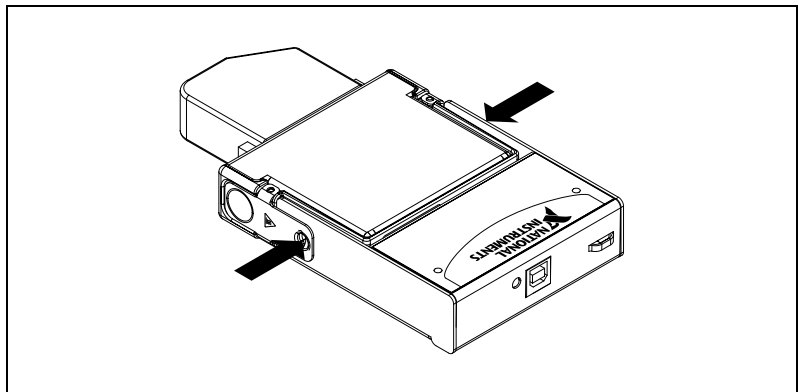

Figure 3. Locking Module into Place

6. Connect the USB cable to the assembled USB-9211/9211A.

Mounting the USB-9211/9211A to a Panel

Threaded inserts are located in the USB-9211/9211A for mounting it to a panel. Refer to Figure 4 for dimensions.

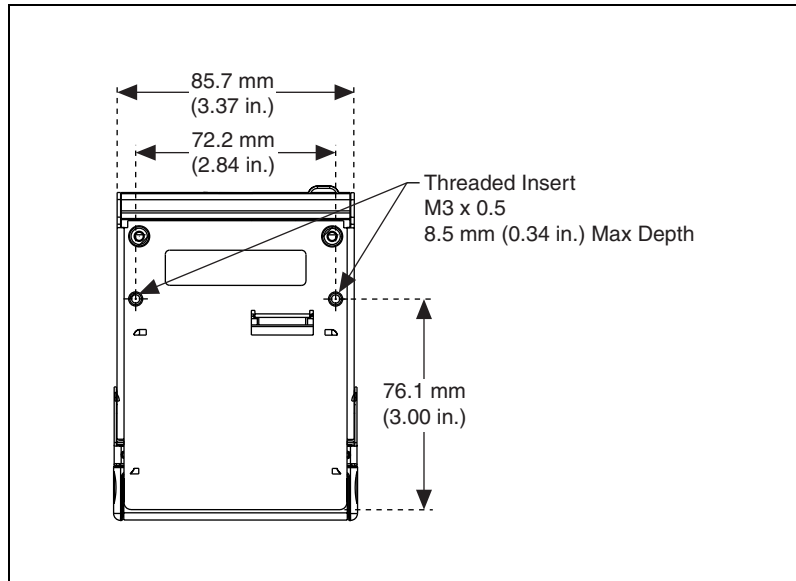

Figure 4. Module Dimensions

Connecting the USB-9211/9211A to a Computer

Plug one end of the USB cable into the USB-9211/9211A and the other end into an available USB port on the computer.

LED Indicator

The LED indicator indicates device status.

Table 2. LED State/Device Status

LED State	Device Status
Not lit	Device not connected or in suspend.
On, not blinking	Device connected, but no module installed.
Single-blink	Operating normally.
Double-blink	Operating normally.
Quadruple-blink	Device error. Refer to ni.com/support .

Wiring the USB-9211/9211A

The USB-9211/9211A has a 10-terminal, detachable high voltage screw terminal enclosure that provides connections for four thermocouple input channels. Each channel has a terminal to which you can connect the positive lead of the thermocouple, TC+, and a terminal to which you can connect the negative lead of the thermocouple, TC-. The USB-9211/9211A also has a common terminal, COM, that is internally connected to the isolated ground reference of the module.



Caution The high voltage screw terminal backshell must be installed when using hazardous voltages ($>42.4 V_{pk}$, 60 VDC).

If you are unsure which of the thermocouple leads is positive and which is negative, check the thermocouple documentation or the thermocouple wire spool. If you are using shielded wiring, connect one end of the shield to the COM terminal.

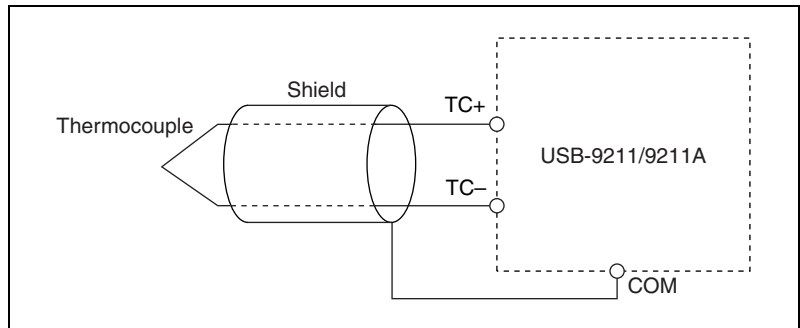
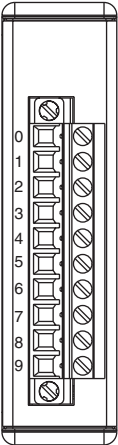

Figure 5. Connecting a Thermocouple Input Signal to the USB-9211/9211A

Refer to Table 3 for the terminal assignments for each channel.

Table 3. Terminal Assignments

Module	Terminal	Signal
	0	TC0+
	1	TC0-
	2	TC1+
	3	TC1-
	4	TC2+
	5	TC2-
	6	TC3+
	7	TC3-
	8	No connection
	9	Common (COM)

Assembling the High Voltage Screw Terminal Backshell

The high voltage screw terminal backshell must be installed when using hazardous voltages ($>42.4 V_{pk}$, 60 VDC). Refer to Figure 6 while completing the following steps:

1. Connect the leads to the screw terminal and secure with the strain relief.
2. Finish by snapping the backshell around the connector.

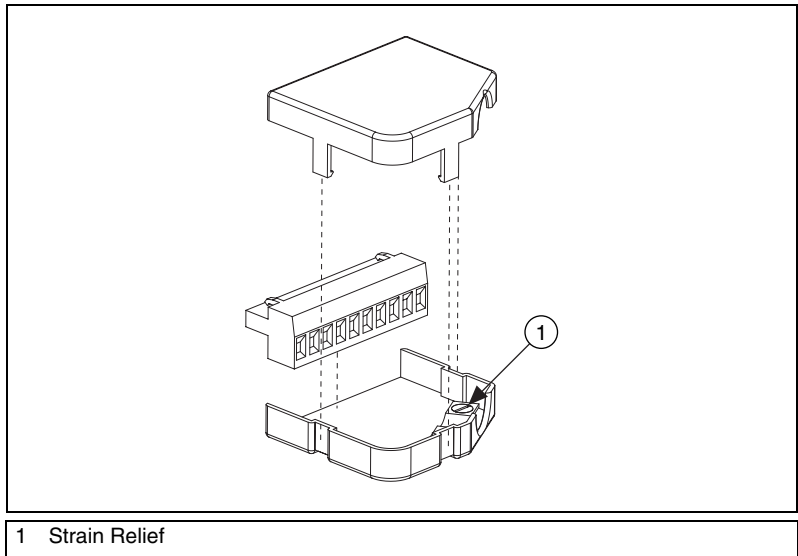

Figure 6. High Voltage Screw Terminal Backshell

USB-9211/9211A Circuitry

The USB-9211/9211A channels share a common ground that is isolated from the chassis and the host computer. Each channel has an impedance between the TC+ and COM terminals and between the TC– and COM terminals. Each channel is filtered and then sampled by a 24-bit analog-to-digital converter (ADC). There is a current source between the TC+ and TC– terminals. If an open thermocouple is connected to the channel, the current source forces a full-scale voltage across the terminals.

Effects of Source Impedance on Voltage Measurement Accuracy

The resistors shown in Figure 7 produce an input impedance at the terminals of the USB-9211/9211A.

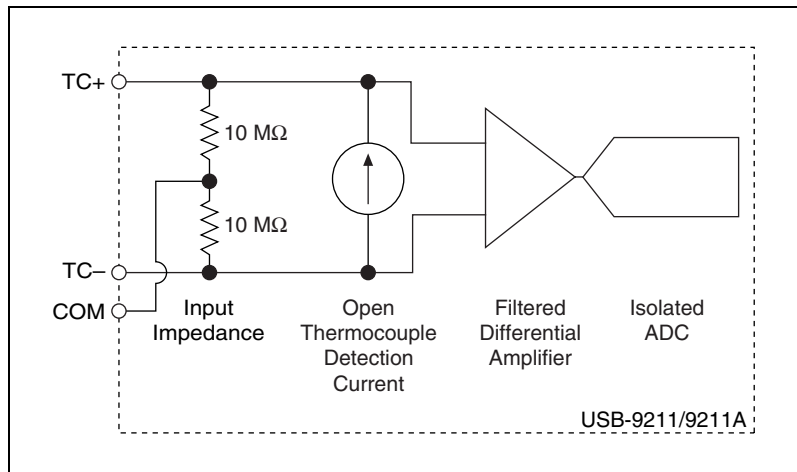

Figure 7. Input Circuitry for One Channel

If thermocouples are connected to the USB-9211/9211A, the gain and offset errors resulting from the source impedance of the thermocouples are negligible for most applications. Other voltage sources with a higher source impedance can introduce more significant errors. For more information about errors resulting from source impedance, refer to the [Specifications](#) section.

Determining Temperature Measurement Accuracy and Minimizing Errors

Temperature measurement errors depend in part on the thermocouple type, the temperature being measured, the accuracy of the thermocouple, and the cold-junction temperature.

Using the Autozero Channel

The USB-9211/9211A has an internal autozero channel for measuring the offset error. If the ambient temperature of the USB-9211/9211A is less than 15 °C or more than 35 °C, use this channel to read the offset error. The USB-9211 always has this channel enabled. Use NI-DAQmx to configure the behavior of the autozero channel for the USB-9211A. Refer to the *NI-DAQmx Help*, accessible from **Start»All Programs»National Instruments»NI-DAQ**, for more information.

Measurement Accuracy for the Different Types of Thermocouples

Figures 8, 9, 10, 11, and 12 show the typical and maximum errors for the different thermocouple types when used with the USB-9211/9211A over the full temperature range. The figures also show the maximum error for the thermocouple types with the USB-9211/9211A at room temperature, 15 to 35 °C. The figures account for gain errors, offset errors, differential and integral nonlinearity, quantization errors, noise errors, and isothermal errors. The figures do not account for the accuracy of the thermocouple itself.

Temperature gradients across the USB-9211/9211A terminals affect the cold-junction temperature accuracy. Refer to the [Cold-Junction Temperature Measurement Accuracy](#) section for more information about temperature gradients.

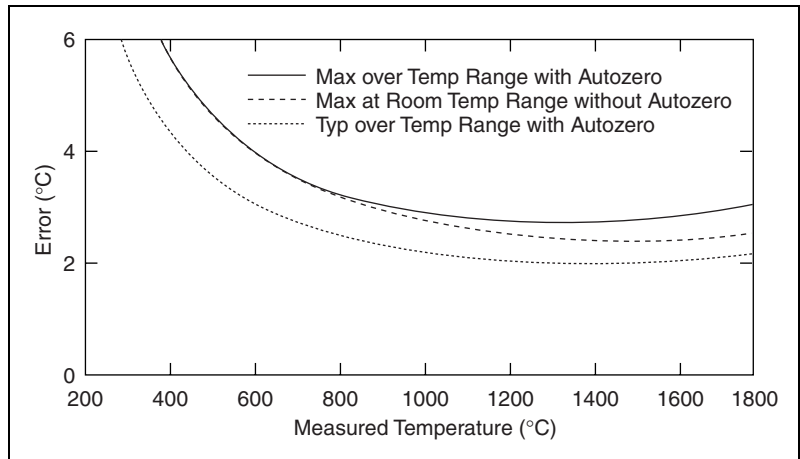

Figure 8. Type B Errors

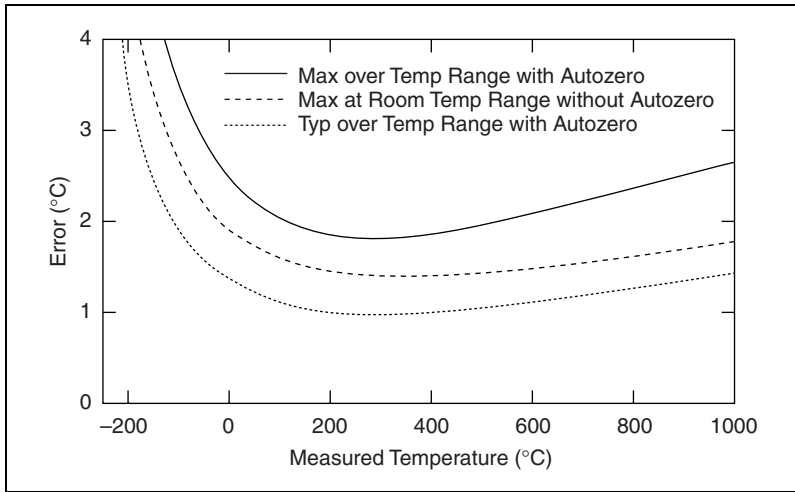

Figure 9. Type E and T Errors

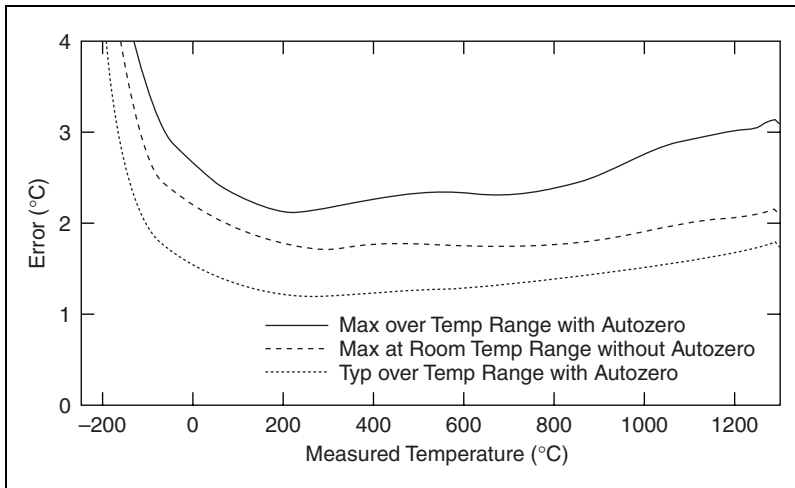

Figure 10. Type J and N Errors

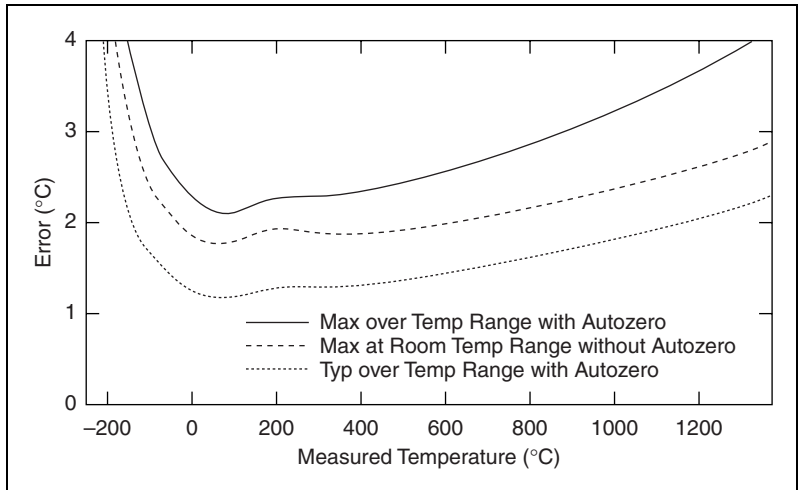

Figure 11. Type K Errors

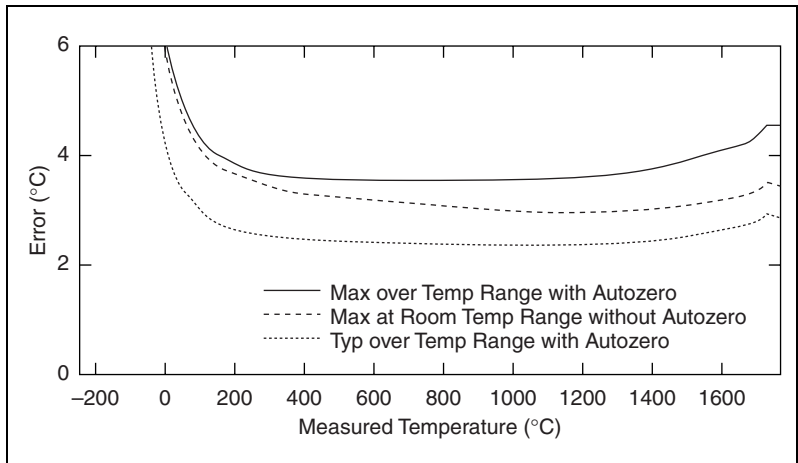

Figure 12. Type R and S Errors

Cold-Junction Temperature Measurement Accuracy

Heat from other nearby heat sources can cause errors in thermocouple measurements by heating up the terminals so that they are at a different temperature than the cold-junction compensation sensor used to measure the cold junction. The thermal gradient generated across the terminals can cause the terminals of different channels to be at different temperatures, so the resulting measurement creates errors not only in absolute accuracy but also in the relative accuracy between channels.

Minimizing Thermal Gradients

Thermocouple wire can be a significant source of thermal gradients if it conducts heat or cold directly to terminal junctions. To minimize these errors, follow these guidelines:

- Use small-gauge thermocouple wire. Smaller wire transfers less heat to or from the measuring junction.
- Run thermocouple wiring together near the screw-terminal connector to keep the wires at the same temperature.
- Avoid running thermocouple wires near hot or cold objects.
- If you connect any extension wires to thermocouple wires, use wires made of the same conductive material.

Specifications

The following specifications are typical at 25 °C, unless otherwise noted.

Input Characteristics

Number of channels	4 thermocouple channels, 1 internal autozero channel, 1 internal cold-junction compensation channel
ADC resolution	24 bits
Type of ADC	Delta-sigma
Voltage measurement range	±80 mV
Common-mode range	
Channel-to-COM	±1.5 V
Common-to-earth ground	±250 V
Common-mode rejection ratio (0 to 60 Hz)	
Channel-to-common	95 dB
Common-to-earth ground	>170 dB
Temperature measurement ranges	Works over temperature ranges defined by NIST (J, K, R, S, T, N, E, and B thermocouple types)

Cold-junction compensation sensor accuracy

0 to 60 °C 0.6 °C (1.1 °F) typ,
1.3 °C (2.3 °F) max

Conversion time 70 ms per channel;
420 ms total for all channels
including the autozero and
cold-junction channels

Max sampling rate (Hz)

Table 4. Max sampling rate (Hz)

Number of Channels in Scan List	Type of Measurement		
	Tempertaure with CJC and Autozero	Temperature with Autozero	RAW (AI)
1	4	6	12
2	3	4	6
3	2.4	3	4
4	2	2.4	3

Note: DAQmx Base always applies autozero.

Input bandwidth (–3 dB) 15 Hz

Noise rejection 85 dB min at 50/60 Hz

Overvoltage protection ±30 V between any input and common

Differential input impedance 20 MΩ

Input current 50 nA

Input noise 1 μV_{rms}

Gain error 0.05% max at 25 °C,
0.06% typ (over temperature)
0.1% max (over temperature)

Offset error (with autozeroing) 15 μV typ, 20 μV max

Gain error from source impedance 0.05 ppm per Ω source impedance
due to input impedance

Offset error from source impedance0.05 μV typ, 0.07 μV max per Ω
source impedance due to input
current

Power Requirements

Current consumption from USB500 mA, max
Suspend mode.....2.5 mA, max

Bus Interface

USB specification
USB-9211USB 2.0 full speed
USB-9211AUSB 2.0 high speed

Physical Characteristics

If you need to clean the module, wipe it with a dry towel.

Dimensions14 cm \times 8.6 cm \times 2.5 cm
(5.51 in. \times 3.37 in. \times 0.99 in.)

WeightApprox. 350 g (12.3 oz)

Screw-terminal wiring12 to 24 AWG wire with 10 mm
(0.39 in.) of insulation stripped
from the end

Torque for screw terminals.....0.5 to 0.6 N \cdot m
(4.4 to 5.3 lb \cdot in.)

Safety

Standards

The USB-9211/9211A is designed to meet the requirements of the following standards of safety for electrical equipment for measurement, control, and laboratory use:

- IEC 61010-1, EN 61010-1
- UL 61010-1
- CAN/CSA C22.2 No. 61010-1



Note For UL and other safety certifications, refer to the product label, or visit ni.com/certification, search by model number or product line, and click the appropriate link in the Certification column.

Voltages

Connect only voltages that are within these limits.

Channel-to-COM ± 30 V max,
Measurement Category I

Measurement Category I is for measurements performed on circuits not directly connected to the electrical distribution system referred to as *MAINS* voltage. *MAINS* is a hazardous live electrical supply system that powers equipment. This category is for measurements of voltages from specially protected secondary circuits. Such voltage measurements include signal levels, special equipment, limited-energy parts of equipment, circuits powered by regulated low-voltage sources, and electronics.

Isolation

Channel-to-channel No isolation between channels

Channel-to-earth ground

Withstand $2,300$ V_{rms}, 5 seconds max

Continuous 250 V_{rms},
Measurement Category II

Measurement Category II is for measurements performed on circuits directly connected to the electrical distribution system. This category refers to local-level electrical distribution, such as that provided by a standard wall outlet (for example, 115 V for U.S. or 230 V for Europe).

Environmental

The USB-9211/9211A device is intended for indoor use only.

Operating temperature

(IEC 60068-2-1 and IEC 60068-2-2) 0 to 60 °C

Storage temperature

(IEC 60068-2-1 and IEC 60068-2-2) -40 to 85 °C

Operating humidity

(IEC 60068-2-56) 10 to 90% RH, noncondensing

Storage humidity

(IEC 60068-2-56) 5 to 95% RH, noncondensing

Maximum altitude 2,000 m (at 25°C ambient temperature)

Pollution Degree (IEC 60664) 2

Electromagnetic Compatibility

Emissions	EN 55011 Class A at 10 m FCC Part 15A above 1 GHz
Immunity	EN 61326-1:1997 + A2:2001, Table 1
EMC/EMI	CE, C-Tick, and FCC Part 15 (Class A) Compliant



Note For EMC compliance, operate this device with shielded cabling.

CE Compliance

This product meets the essential requirements of applicable European Directives, as amended for CE marking, as follows:

Low-Voltage Directive (safety).....73/23/EEC

Electromagnetic Compatibility
Directive (EMC).....89/336/EEC



Note Refer to the Declaration of Conformity (DoC) for this product for any additional regulatory compliance information. To obtain the DoC for this product, visit ni.com/certification, search by model number or product line, and click the appropriate link in the Certification column.

Calibration

You can obtain the calibration certificate for the USB-9211/9211A at ni.com/calibration.

Calibration interval.....1 year

Where to Go for Support

The National Instruments Web site is your complete resource for technical support. At ni.com/support you have access to everything from troubleshooting and application development self-help resources to email and phone assistance from NI Application Engineers.

National Instruments corporate headquarters is located at 11500 North Mopac Expressway, Austin, Texas, 78759-3504. National Instruments also has offices located around the world to help address your support needs. For telephone support in the United States, create your service request at ni.com/support and follow the calling instructions or dial 512 795 8248. For telephone support outside the United States, contact your local branch office:

Australia 1800 300 800, Austria 43 0 662 45 79 90 0,
Belgium 32 0 2 757 00 20, Brazil 55 11 3262 3599,
Canada 800 433 3488, China 86 21 6555 7838,
Czech Republic 420 224 235 774, Denmark 45 45 76 26 00,
Finland 385 0 9 725 725 11, France 33 0 1 48 14 24 24,
Germany 49 0 89 741 31 30, India 91 80 51190000,
Israel 972 0 3 6393737, Italy 39 02 413091, Japan 81 3 5472 2970,
Korea 82 02 3451 3400, Lebanon 961 0 1 33 28 28,
Malaysia 1800 887710, Mexico 01 800 010 0793,
Netherlands 31 0 348 433 466, New Zealand 0800 553 322,
Norway 47 0 66 90 76 60, Poland 48 22 3390150,
Portugal 351 210 311 210, Russia 7 095 783 68 51,
Singapore 1800 226 5886, Slovenia 386 3 425 4200,
South Africa 27 0 11 805 8197, Spain 34 91 640 0085,
Sweden 46 0 8 587 895 00, Switzerland 41 56 200 51 51,
Taiwan 886 02 2377 2222, Thailand 662 278 6777,
United Kingdom 44 0 1635 523545

National Instruments, NI, ni.com, and LabVIEW are trademarks of National Instruments Corporation. Refer to the *Terms of Use* section on ni.com/legal for more information about National Instruments trademarks. Other product and company names mentioned herein are trademarks or trade names of their respective companies. For patents covering National Instruments products, refer to the appropriate location: **Help»Patents** in your software, the `patents.txt` file on your CD, or ni.com/patents.